

**1st secondary
education**

Physical Education

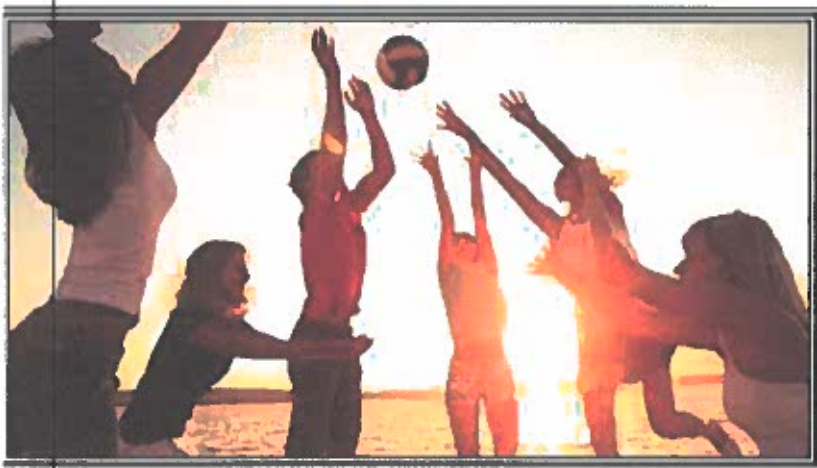

Student:

Group:

Cortes de Cádiz Secondary School

El Molar

P. E. department

Index

☉	WELCOME!	3	
☉	OBJECTIVES OF THIS COURSE	4	
☉	EVALUATION	4	
☉	PARTS OF THE HUMAN BODY	5	
☉	SPORT EQUIPMENT	6	
☉	I. HEART RATE	7	
	✓ HEART RATE ASSESSMENT I	9	
	✓ HEART RATE ASSESSMENT II	11	
☉	II. WARM UP	13	
	✓ WARM UP ASSESSMENT I	14	
	✓ WARM UP ASSESSMENT II	15	
☉	III. LOCOMOTOR SYSTEM	16	
✗	MUSCULAR SYSTEM	16	
	✓ MUSCULAR SYSTEM ASSESSMENT	17	
✗	SKELETAL SYSTEM	18	
	✓ SKELETAL SYSTEM ASSESSMENT I	19	
	✓ SKELETAL SYSTEM ASSESSMENT II	20	
☉	IV. HEALTH AND FITNESS	21	
☉	V. FITNESS	22	
	✓ FLEXIBILITY ASSESSMENT	23	
	✓ STRENGTH ASSESSMENT	24	
	✓ FITNESS ASSESSMENT I	25	
	✓ FITNESS ASSESSMENT II	26	
	✓ PHYSICAL CONDITION TESTS	27	
☉	VI. FIRST AID	28	
	✓ FIRST AID ASSESSMENT	30	
☉	VII. POSTURE	31	
	✓ POSTURE ASSESSMENT	33	
☉	VIII. BADMINTON	34	
	✓ BADMINTON ASSESSMENT	36	
☉	IX. HANDBALL	37	
	✓ HANDBALL ASSESSMENT	39	
☉	X. ORIENTEERING	40	
	✓ ORIENTEERING ASSESSMENT	43	
☉	XI. HIKING	44	
	✓ HIKING ASSESSMENT	45	
☉	XII. GIMNASTICS AND ACROGYM	46	
	✓ GIMNASTICS AND ACROGYM ASSESSMENT	48	
☉	SMALL READING	49	



P.E.

Welcome!

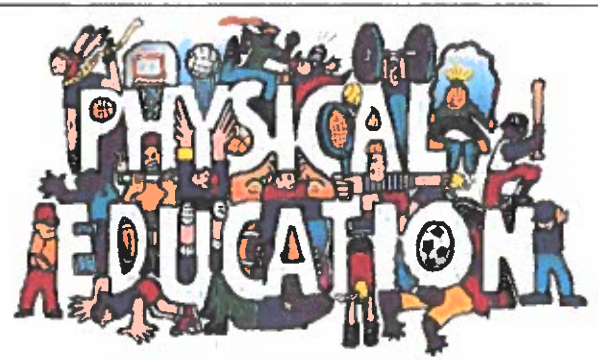

WHAT WE NEED THROUGH THIS COURSE

Before coming to school

- **Having a good breakfast:** we need you full of beans, full of energy! And we obtain this energy from food. So we need to have a good breakfast. What's a good breakfast? A good breakfast is not a lonely glass of milk. A glass of milk is ok, but we can drink it with some cola – cao, and add corn flakes, we can eat a toast first, or some fruit, or a natural orange juice, or some biscuits...



- **Having a good rest:** as important as work is to rest (regeneration of the body during sleep), in order to be ready to do properly as many tasks as possible all day long.

At school

- Sports clothing
- Trainer / Sneakers

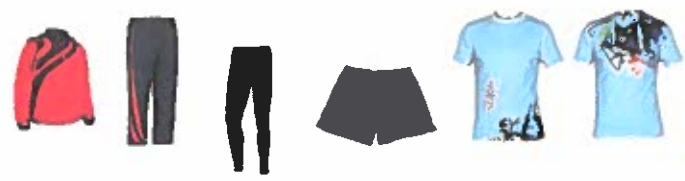

- Take care of our personal hygiene: you should wash with water after doing exercise, as well as putting on another clean t-shirt (you can also use cologne or deodorant).



- Respect a fellow



- Punctuality : of course, we need to be on time at the beginning of each session, because we want to be able to do many different activities.



- Movement: we need to make a great effort during every session as a way to be able to improve and to make the best of ourselves!

- Learn! Enjoy!



Finally, we can't choose, we'll have to speak in English. It's going to be hard for everyone, but we need to make an effort.



OBJECTIVES OF THIS COURSE

1.- LEARN new things



2.- PROGRESS and be more physically skillful.

3°.- LEARN to interact better with others.



4.- LEARN to take care and respect both the facilities and the material that not everyone can have.

they are just what you

5°.- LEARN to make an effort and improve yourself with skills we will teach you. They will help you, and need for your total life.



6°.- LEARN to have fun in a group or alone in a new way.

EVALUATION

1.- You will be evaluated by doing PRACTICAL TESTS in class...



2.- ... by WRITTEN TESTS about what you are going to read in this notebook...



«Yeah, you've read right ».

It is high time that you know why you do things and think about it, and for this you need to know some **THEORY**

3.- ...and by how you do things EVERY SINGLE DAY.

You know, that you retain what is learned, that you know how to relate what you've learned to other things, the interest you show in class, your responsibility to accept the rules of coexistence...

Can we speak Spanish? No we can't
Should we speak English? Yes, we should.



PARTS of the human body







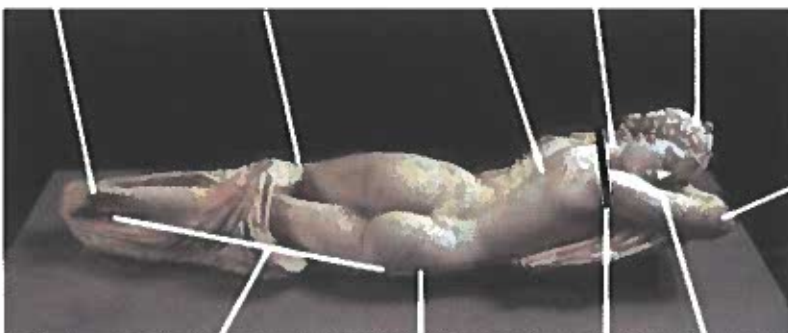
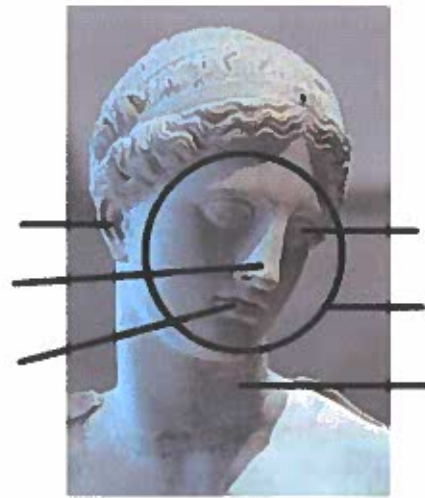



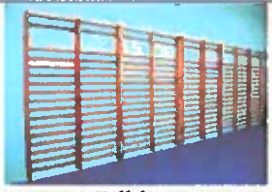









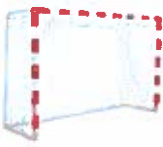





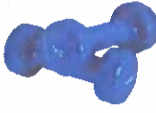

Name and surname: _____ Class group:

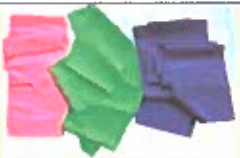
—

Where are each of the following body parts?: abdomen, ankle, arm, back, chest, ear, elbow, eye, face, fingers, forearm, foot, hair, hand, head, heel, hip, knee, leg, lips, neck, mouth, nose, palm, teeth, thigh, toes, tongue, shoulder, thorax, wrist. Also, translate these words into Spanish.



Sport equipment

 Wall bars	 Balls	 Bars	 Rope
 Cone	 Cones	 Plinth	 Vaulting horse
 Bench	 Mat	 Net bag	 Hoops
 Goal	 Basket/ basket ball net	 Baseball bat	 Curtain divider
 Sticks	 Net	 Shuttlecock	 Dumbbells
 Racquets	 Compass	 Whistle	 Stopwatch
 Elastic band	 Relay baton	 Frisbee	 Fitness mat
 Juggling balls	 Volleyball poles	 Mini trampoline	 Medicine balls

1.- Heart rate

Heart rate is the number of times that our heart beats per minute. We can feel it at points in the body where the arteries are near to the skin. For normal adult when resting this will be between 60 and 90 beats per minute.

2.- Why do we have to know it?

Because it gives us a basic idea of our health; when we are training it indicates whether the effort we are making is slight, soft, heavy or excessive. It is measured in beats per minute.



So we know that at rest:

- ✓ - 60 beats per minute: a very healthy heart.
- ✓ 60-80/90 beats per minute: the normal heart rate of a human being.
- ✓ 90-100 beats per minute: if repeated over time, you need to consult your doctor.
- ✓ +100 beats per minute: a pathological or diseased heart (consult your doctor)

3.- Our heart rate and sport.

Our heart is a muscle and, as every muscle, with healthy sport it becomes stronger and bigger. What happens then? If our heart is bigger, then it can have more blood inside it, and it is going to pump more blood in every beat.

When we are resting, our heart has to pump between 5 – 6 litres of blood per minute. If, as we said before, our heart is bigger, it will need fewer beats to pump those 5 – 6 litres per minute. So that is why our heart rate slows when we do regular exercise.

4.- How can we measure our heart rate?

We have three main points to measure our heart rate. It is measured in the wrist and the neck with the index and middle fingers (never with thumb, it is very sensitive and it can make us to count more beats), and in the chest with the palm of the hand.

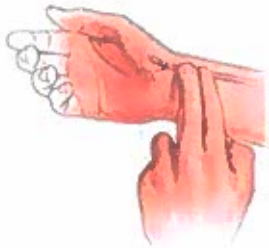

Radial artery (wrist)



Carotid (neck)



Heart (chest, left side)

5.- How much time do we need to measure our heart rate?

It depends on whether we are resting or we have just finished an exercise:

- When we are resting we usually measure our heart rate in one minute, or we can measure it in half minute, and multiply by two.

$$\underline{30'' \times 2 \quad / \quad 60'' \times 1}$$

- After exercise, during the first minute after finishing it, our body starts to recover, and our heart rate becomes lower. That is why we are going to measure our heart rate using one of the following options:

$$\underline{6'' \times 10 \quad / \quad 10'' \times 6 \quad / \quad 15'' \times 4}$$

6.- How can we improve our heart rate?

Doing physical exercise. To improve cardiovascular health we need efforts that are located between 60 – 85% of maximum heart rate.

How can we find which is our maximum heart rate?

In this way (approximately): **220 - age**

Our maximum heart rate decreases with age, which means that the older we are, the less appropriate intensive exercises are.

Physical activity is essential in order to keep a good fitness, to control our weight and to have a good cardiovascular system. All adults should do at least 30 minutes of exercising a day of moderate intensity (50% of HR maximum or more).



In the theme, we have seen some theoretical ideas about the pulse. Now, we are going to see it from a practical way.

Heart rate assessment I

1. Follow the table and take your pulse after each activity.

	ACTIVITY	BPM	Nº	ACTIVITY	BPM
1	Lying down		7	20 squats – 20 abd – 12 push ups	
2	Sitting		8	3' later	
3	Standing (resting)		9	50 meter sprint	
4	1' walking fast		10	3' later	
5	5' continuous running (120 bpm – 160 bpm)		11	45"-1' anaerobic running	
6	3' later		12	3' later	

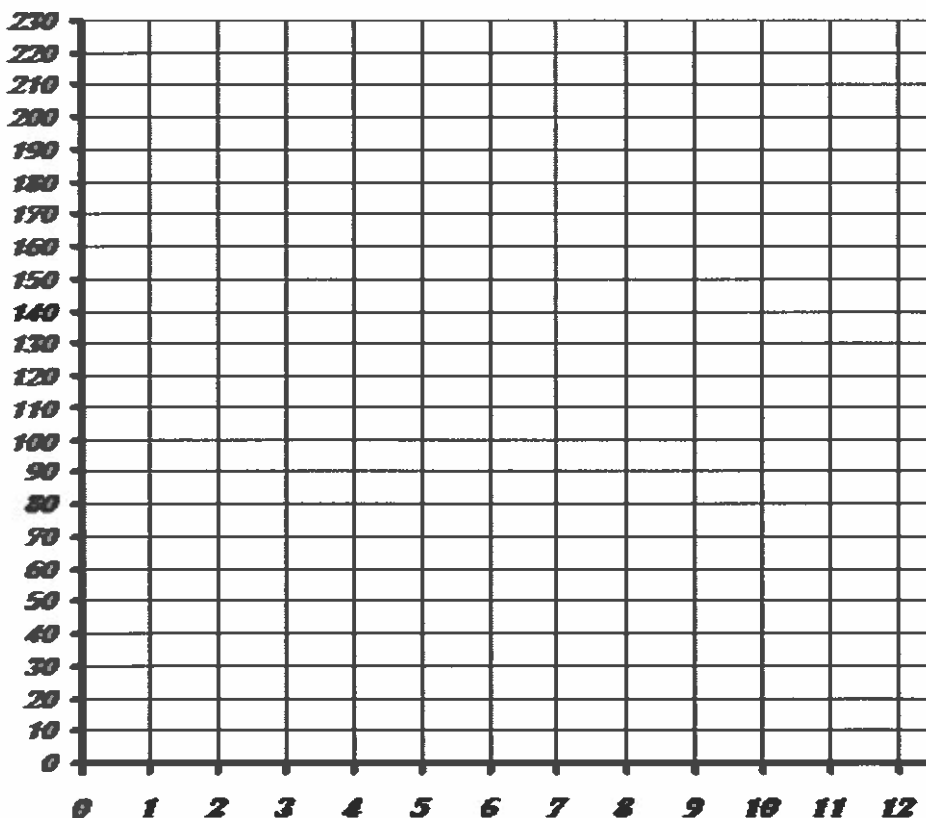

2.- Transfers the result of the table to the graph.

3.- Draw a point on the intersection between every activity and its beats per minute (bpm).

Example: if in number one activity you had 70 bpm you have to draw a point when both lines intersect

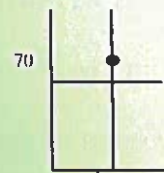

4.- Connect all points with a solid line.

5.- Now, you have to answer the questions on the next page.

Name and surname: _____

Class group: _____ Date: _____

Qualification: _____



Questions:

1.- Is your resting pulse normal? Why?

2.- About our resting heart rate, say whether the following statements are true or false:

- Someone who has less than 60 beats per minute (bpm) is in really bad physical condition.
- It's normal to have 79 bpm.
- If I would have 95 bpm in many times, I should go to the doctor.
- If I would have 105 bpm, I should go to the doctor.
- If a person has 49 bpm then is ill.

3.- Say whether the following statements are true or false:

- When we are doing exercises our muscles need more oxygen.
- The oxygen is carried by blood.
- The faster we run, the fewer beats per minute we have.
- We usually have more bpm when we are running one hour than when we run really fast for one hundred metres.
- As a rule, the more muscles take part in an exercise, the more bpm we have.

4.- How did you do in exercise number 5? (5' continuous running at 120 – 160 bpm): (right or wrong). Why do you say that?

5.- Say whether the following statements are true or false:

- It is normal in the anaerobic running (1' running really fast) to have more than 180 bpm.
- If we have more than 200 bpm it means that we have ran really fast.
- It is possible to run fast having 120 bpm.
- The slow we run, the more beats per minute we have.

6.- If you have a good recovery time, what number of beats should you have after 3' resting?

If your heart rate after 3' resting is higher than that number, what does it mean?

7.- Which are the three main points to measure our heart rate? How do we have to do it?

Heart rate assessment II

Choose, for each question, which answer is the right one:

1) What is heart rate?

- a) It is the number of times that our heart beats in our life.
 - b) It is the number of times that our heart beats per minute.
 - c) It is a point in the body where the arteries are close to the skin.
 - d) It is the way we do exercise.
-

2) What is our normal heart rate?

- a) – 60 beats per minute
 - b) Between 60 and 90 beats per minute.
 - c) Between 90 and 100 beats per minute.
 - d) More than 100 beats per minute.
-

3) What is our normal heart rate when we exercising?

- a) – 60 beats per minute
 - b) Between 60 and 90 beats per minute.
 - c) Between 90 and 120 beats per minute.
 - d) More than 120 beats per minute.
-

4) What happen to our resting heart rate if we do running four days a week for many years?

- a) It becomes bigger.
 - b) It becomes smaller.
 - c) It stays the same.
 - d) It is impossible to know.
-

5) Why does it happen?

- a) Because our heart becomes bigger and is able to pump more blood on every beat.
 - b) Because our heart becomes smaller and has to pump blood faster.
 - c) Because our heart becomes stronger.
 - d) None of these reasons.
-

6) How do we have to measure our heart rate?

- a) Using our thumb, putting them on the wrist.
 - b) Using our index and middle fingers, and putting them on the thumb.
 - c) Putting any part of our body on the wrist, the neck or the chest.
 - d) Using our index and middle fingers, putting them on the wrist or the neck, or putting our hand on the chest.
-

7) How much time do we need to measure our heart rate when we are resting?

- a) Ten seconds.
 - b) One minute.
 - c) At least one minute.
 - d) No less than one minute.
-



8) After exercising, if we want to know what our heart rate is we have to measure it using one of the following options: 6" x 10; 10" x 6; 15" x 4. Why don't we measure it in one minute?

- a) It's ok measure it in one minute.
 - b) Because waiting for one minute is too boring.
 - c) Because we can lose the count of our beats.
 - d) Because if we need a long time to measure it, then our heart rate is not our exercising heart rate, but our resting heart rate.
-

9) How can we improve our heart rate?

- a) Running four days a week.
 - b) Cycling five days a week.
 - c) Walking one hour a day.
 - d) a), b) and c) are all correct.
-

10) How can we improve our heart rate?

- a) Doing efforts that are located between 60 – 85% of maximum heart rate.
 - b) Doing efforts that are located no more than 60% of maximum heart rate.
 - c) Doing any kind of efforts.
 - d) Doing only cardiovascular efforts of no more than ten minutes.
-

11) What is the maximum heart rate of Carlota if she was born twenty-seven years ago?

- a) 193 beats per minute.
 - b) Between 60 and 90 beats per minute.
 - c) 220 beats per minute.
 - d) We can't know it.
-

12) What happen with our maximum heart rate throughout our life?

- a) It increases.
 - b) It decreases.
 - c) It keeps on in the same way.
 - d) We can't know it.
-

13) What does it mean?

- a) When we are old, we can't do any kind of exercise.
 - b) It means nothing.
 - c) When we are old, we can't run for a long period of time (for example, for one hour or more).
 - d) When we are old, we can't do intensive exercise.
-

14) If you have a good recovery, what number of beats should you have after 3' resting?

- a) Between 60 and 90 beats per minute (bpm).
 - b) Fewer than 120 beats per minute.
 - c) Fewer than 150 bpm.
 - d) The same as resting.
-

Name and surname: _____

Class group: _____ Date: _____ Qualification: _____

1.- What is a warm up?

Moderate and progressive exercises performed before a more intense exercise (a physical activity as work out, a match, a competition...).

2.- Objectives of the warm up:

- ✗ To avoid the risk of injuries during the activity.
- ✗ To improve our performance (the warm up prepares the person for the following effort, physically, physiologically and psychologically).

3.- How do we perform warm up? (what do we have to take into account when performing the warm up). The warm up should include:

- ✗ Gentle exercise for the whole body, such as light jogging. This gradually increases heart rate, breathing and blood supply to the muscles. It increases our muscles temperature and prepares us mentally for the session.
- ✗ Exercises to move all the parts of your body, from your head to your toes.
- ✗ Gentle stretching, to prepare muscles, ligaments and joints.
- ✗ Practising techniques and skills to be used in the session.
- ✗ End up with dynamic activities: games and some sprints or short fast races.
- ✗ It has to be progressive, from low-intensity to high-intensity exercises.
- ✗ It should last at least 10' or 15'.
- ✗ Do not get tired, don't make too many repetitions of each movement and alternate the parts of the body you are moving.

1.- Gentle **stamina** exercises, as light jogging and displacements exercises

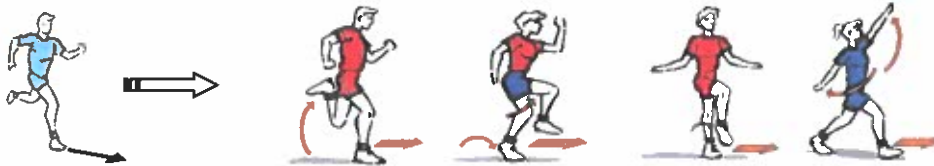

2.- **Flexibility** exercises for legs, trunk and arms (4 for each zone is ok).



Legs (20'')

Trunk (20'')

Arms (20'')

3.- **Strength** exercises for legs, trunk and arms (1 for each zone is ok).



Legs

Trunk

Arms

(We can also finish with dynamic activities like games or sprints)

Warm up assessment I

Name and surname: _____ Class: _____

1. What do we have to do first when we want to start a physical activity or sport?

1. What is the warm up?

2. What are the two main objectives of the warming up?

✓

✓

3. What kind of exercises do we have to do during a warm up? In which order? Write an example of one exercise for each of them.

Order of exercises	Type of exercise	Example (write one exercise)
1		
2		
3		

4. Write each exercise in the correct order in which you would perform during a warm up (there is one extra, that we NEVER should do in the warm up: cross it off):



Warm up assessment II

Write on this page a general warm up (choose your own exercises, don't copy those you have read in the previous pages)

1  3' de c.c.	2	3	4	5
6	7	8	9	10
11	12	13	14	15
16	17	18	19	20

Name and surname: _____

Group: _____ Qualification: _____



The locomotor system gives humans the ability to move and it is made up by the following systems:

- ▶ Muscular system:
muscles, tendons
- ▶ Skeletal system:
skeleton, joints, ligaments

1.- What does our muscular system do?

- ✗ Enable us to move the parts of our body.
- ✗ Give us our individual shape.
- ✗ Protect and keep in place our abdominal organs.
- ✗ Enable us to maintain a good posture.
- ✗ Hold in blood circulation.
- ✗ Generate body heat when they contract.

2.- Our muscles and sport:

Our muscles increase in size and strength when we follow a regular programme. This is called hypertrophy. When we do not use our muscles regularly they get smaller and weaker. We call this muscle atrophy. This loss of size and strength often happens when we are recovering from an injury. If we are waiting for a particular injury to heal we should try to exercise the rest of the body as much as possible.

3.- What is the muscular system formed by?

- ☛ **Muscles:** tissue in a human (or animal) body that has the ability to contract, producing the movement of our body and maintaining our body posture.
- ☛ **Tendons:** tough and flexible band that connects muscles to bones

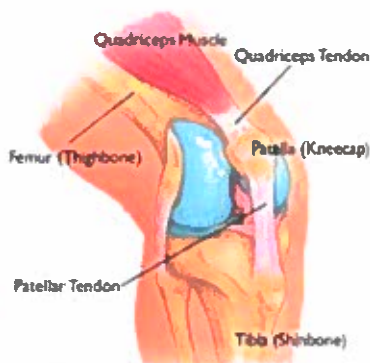

Patellar tendon

Achilles tendon



Muscular system assessment

Translate into Spanish the name of the following muscles. Identify in what part of the body these muscles are found:

- Biceps _____
- Triceps _____
- Deltoid _____
- Pectorals _____
- Abdominals _____
- Trapezius _____
- Lumbar _____
- Latissimus dorsi _____
- Quadriceps _____
- Hamstrings _____
- Adductor _____
- Gastrocnemius _____
- Gluteals. _____

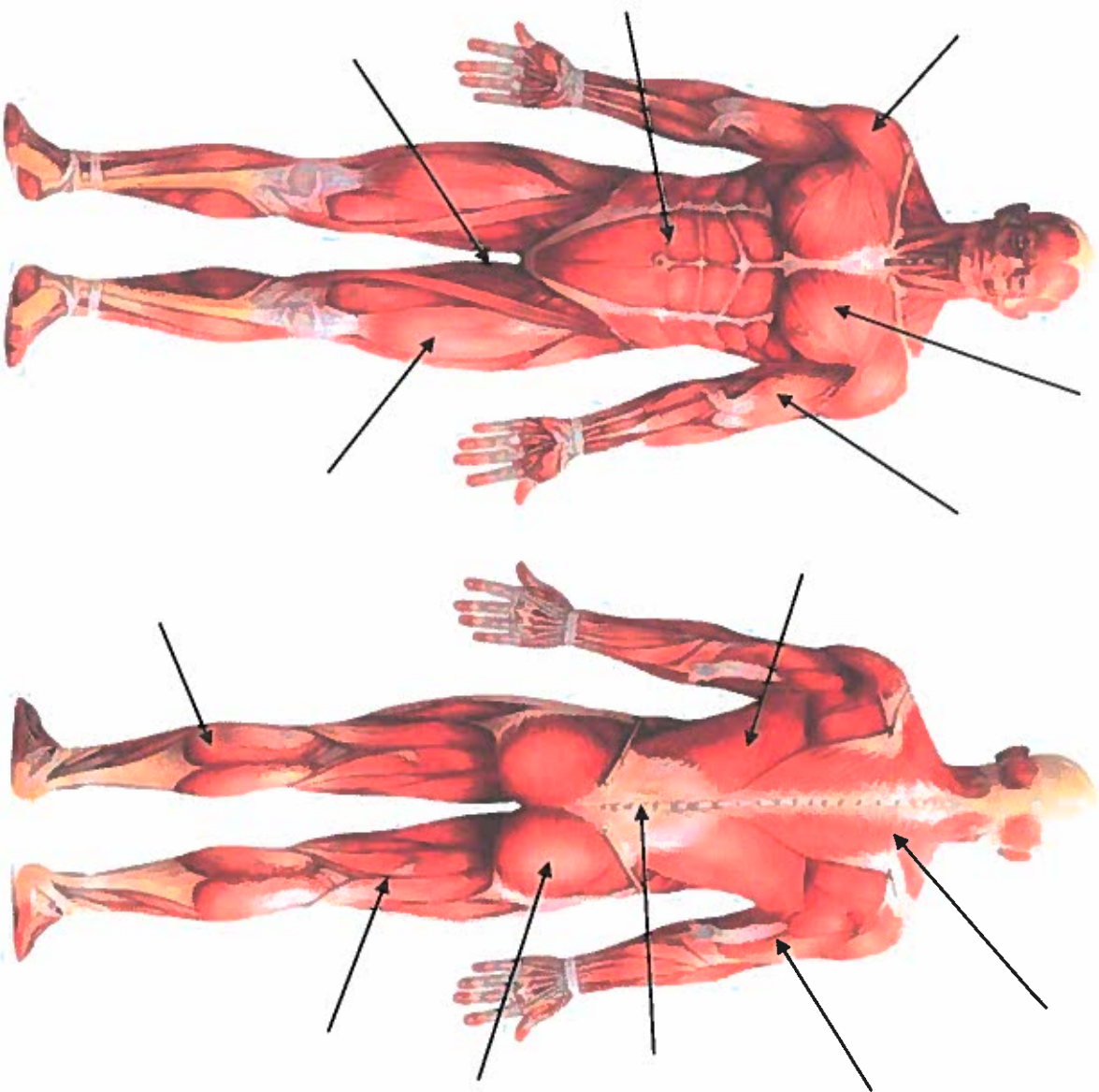

Name and surname: _____

Group: _____

Qualification: _____

1.- What does our skeleton do?

- × Protects our delicate organs:
 - ✚ The skull protects the brain.
 - ✚ The vertebral column protects the spinal cord.
 - ✚ The rib cage protects the heart and lungs
- × It is a framework for our body:
 - ✚ The skeleton gives shape to our bodies.
 - ✚ It holds our vital organs in place.
 - ✚ It enables us to achieve a good posture.
- × Moves (our muscles use our bones to cause movement):
 - ✚ The skeleton provides attachment for the muscles.
 - ✚ The skeleton is jointed, which allows a wide range of movement.
 - ✚ Different joints allow different types of movement.
- × Produces blood:
 - ✚ Red and white blood cells are produced in the bone marrow of the ribs, humerus, vertebrae and femur.



2.- Our skeletal system and sport:

Exercise helps to develop the skeleton in young people, while we are growing up. Exercise can increase bone width, bone density and bone strength. However, we need to choose the exercises properly, because some of them can be dangerous: lifting heavy weights during the growing period can damage normal growth.

3.- Bones and joints:

The adult human body is made up of about 206 bones, which are tough, light and strong. These bones are joined together by many joints (we have over 100 different joints in our bodies). A joint is a place where two or more bones meet.

There are three groups of joints, based on the amount of movement they allow:

- ⊙ Freely movable joints: its movements are extensive (knee, hip, shoulder...).
- ⊙ Slightly movable joints: its movements are slight (joints of the vertebral column, joints between the ribs and sternum).
- ⊙ Immovable joints: no movement is possible between the bones (as it happens in the skull, or in the pelvic girdle).



Freely movable joints
(Shoulder)



(Hip)



Slightly movable joints
(Vertebral column)



Immovable joints
(Skull)

Skeletal system assessment (I)

1.- Translate the following bones into Spanish.

ENGLISH	SPANISH
Skull	
Clavicle	
Sternum	
Ribs	
Vertebrae	
Coxal	
Sacrum	
Patella	
Femur	
Tibia	

Fibula	
Tarsals	
Metatarsals	
Phalanges of the foot	
Scapula	
Humerus	
Radius	
Ulna	
Carpals	
Metacarpals	
Phalanges of the hand	

2.- Point out where the bones named in exercise 1 are (write its names in English):

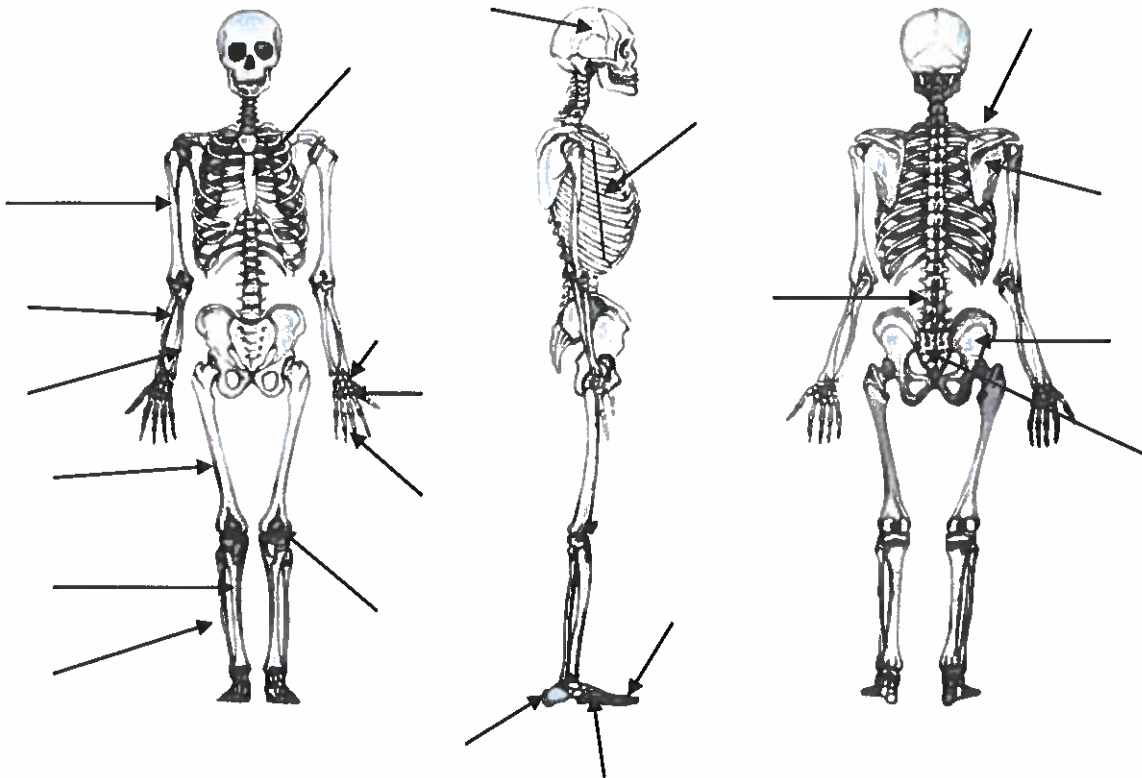

Name and surname:

Group:

Skeletal system assessment (II)

Name and surname: _____ Group: _____



- 1) Name the three bones in the arm.
- 2) Write the main four functions of the skeleton.

3) In what body parts are phalanges?

4) Complete the following sentences:

- ☀ The brain is protected by...
- ☀ The spinal cord is protected by...
- ☀ Our heart and lungs are protected by...

5) What groups of joints do we have?

6) Name the four bones in the leg.

7) What are the effects of sport on our skeletal system?

8) Write whether it's true or false each of the following statements (and, if it's false, explain briefly why)

- ✗ Our bones use our muscles to cause movement.
- ✗ Exercise helps the development of the skeleton in young people.
- ✗ All our bones protect the organs of our body.
- ✗ A joint is a place where one bone meets.
- ✗ The joints between the ribs and sternum are immovable joints.
- ✗ If we don't do physical activity regularly, our bones will become weak.





"What fits your busy schedule better, exercising one hour a day or being dead 24 hours a day?"

Good health: according to the World Health Organization, it is a state of complete physical, social and mental wellbeing, and not only the absence of disease. We are in good health when the physical, mental, cultural and social aspects of our lives are all working well together. We are able to lead a full and active life combining work, recreation and social activities without becoming exhausted.

In order to have a good health we should:

Eat sensibly.

Do regular physical activity.

Get regular rest and sleep.

Limit our intake of alcohol.

Not smoke tobacco or any other social drugs.

Improve our ability to cope with stress.



Fitness: is the condition of being physically fit, which means that our body is able to carry everyday activities with little fatigue and with enough energy.

There is a minimal level of fitness, which we all need in order to have a good health. Fitness is also crucial to success in sport. It is essential for us to look at the particular demands of sport (or our life) and identify in what ways we need to develop our fitness.

There are many different kinds of sporting activities; each makes its own particular demands on the body but, as a rule, if we want to improve our physical fitness we have to develop its various components:



STRENGTH

SPEED

STAMINA

FLEXIBILITY

STAMINA

1.- What is it?

Stamina is the ability to work for relatively long periods of time without becoming tired. The better our stamina is, the longer we can continue our activity, whether it is swimming, running, cycling or rowing.



STRENGTH

1.- What is it?

Strength is the ability to carry weights or overcome resistances using our muscles (it allows us to move or to raise things).



FLEXIBILITY

1.- What is it?

Flexibility is the ability to perform movements with significant extent. It helps us to reduce the risk of injuries by increasing the range of movement from a joint. Flexibility also allows us to use our strength through a full range of movement.

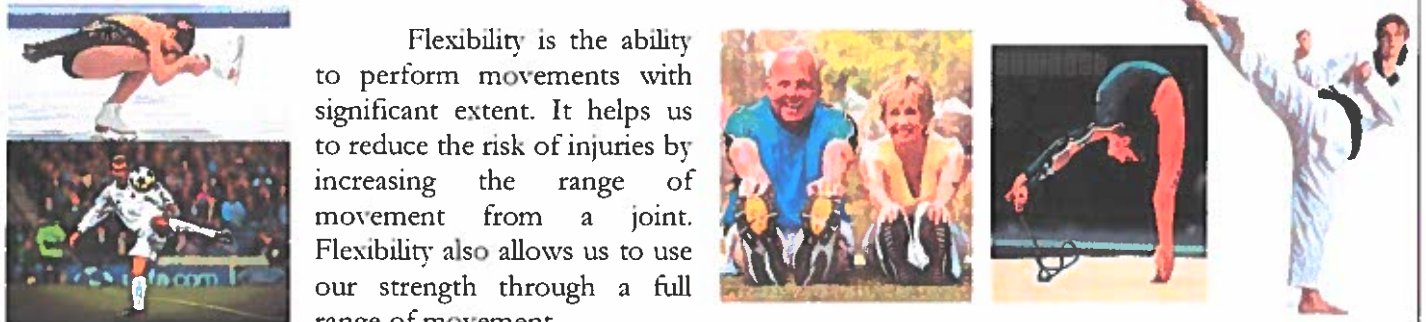

SPEED

1.- What is it?

Speed is the ability to perform an action as quickly as possible. (It is the ability to move all or part of the body as quickly as possible). Speed does not mean just running, but it is present in many aspects of sport.

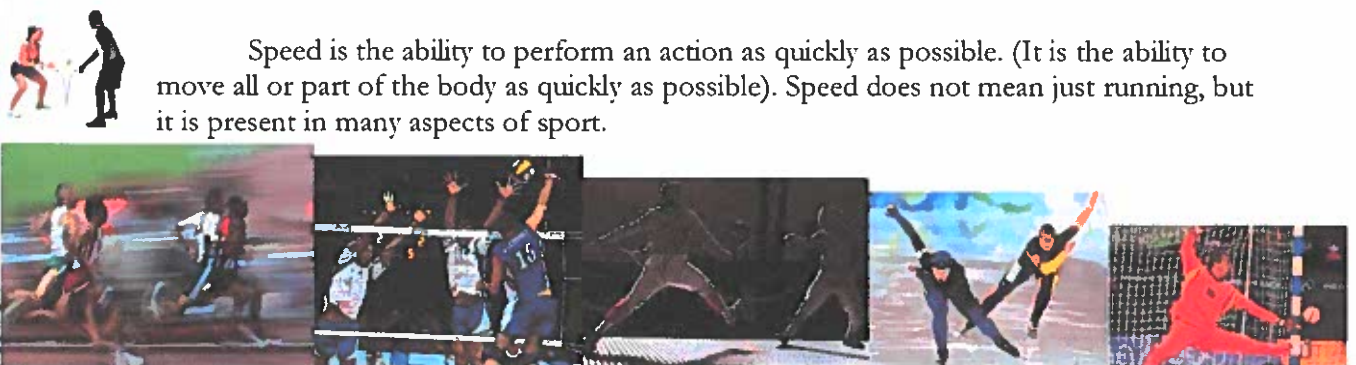

Flexibility assessment

NAME AND SURNAME: _____ CLASS: _____

Match every picture with the muscle being worked on

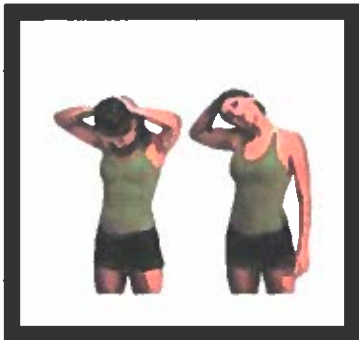

Adductor

Abdominals

Deltoid



Gastrocnemius

Gluteals



Hamstrigs

Lumbar



Latissimus dorsi

Pectorals

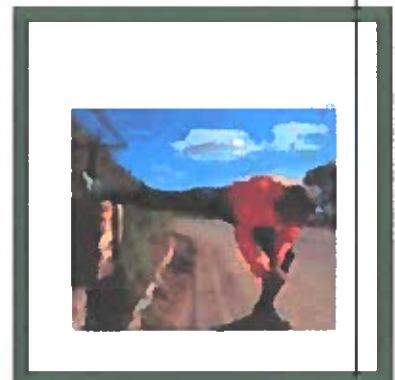
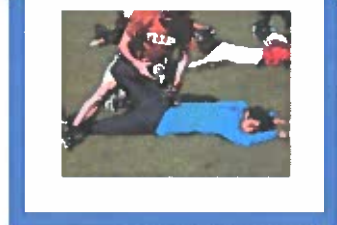

Quadriceps











Trapezius

Triceps

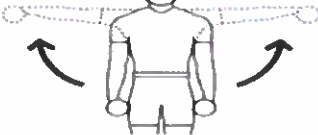

Strength assessment

Match every picture with the muscle being worked on

	EXERCISE	WORKED MUSCLE
Knees bent (or flexed), hands behind the head; trunk up and down		
Swedish gym bench behind us, hands on it, extended legs, flex and extend elbows.		
Squats.		
Legs extended, cross them.		
Move arms laterally up and down (elbows extended) until your hands reach shoulder height.		
Jumping rope (on tiptoes).		
Lying face down, face on the ground, alternately raise opposite arm and leg.		
Hands on the wall bar, bend and straighten elbows.		
Hands and knees on the floor, one leg in the air (extended), flex and extend it.		

FLEXIBILITY EXERCISES (draw one for each muscle)

Quadriceps	Hamstrings	Adductor	gastrocnemius	Gluteal

Fitness assessment

For each exercise, write which component of our physical fitness is being worked:

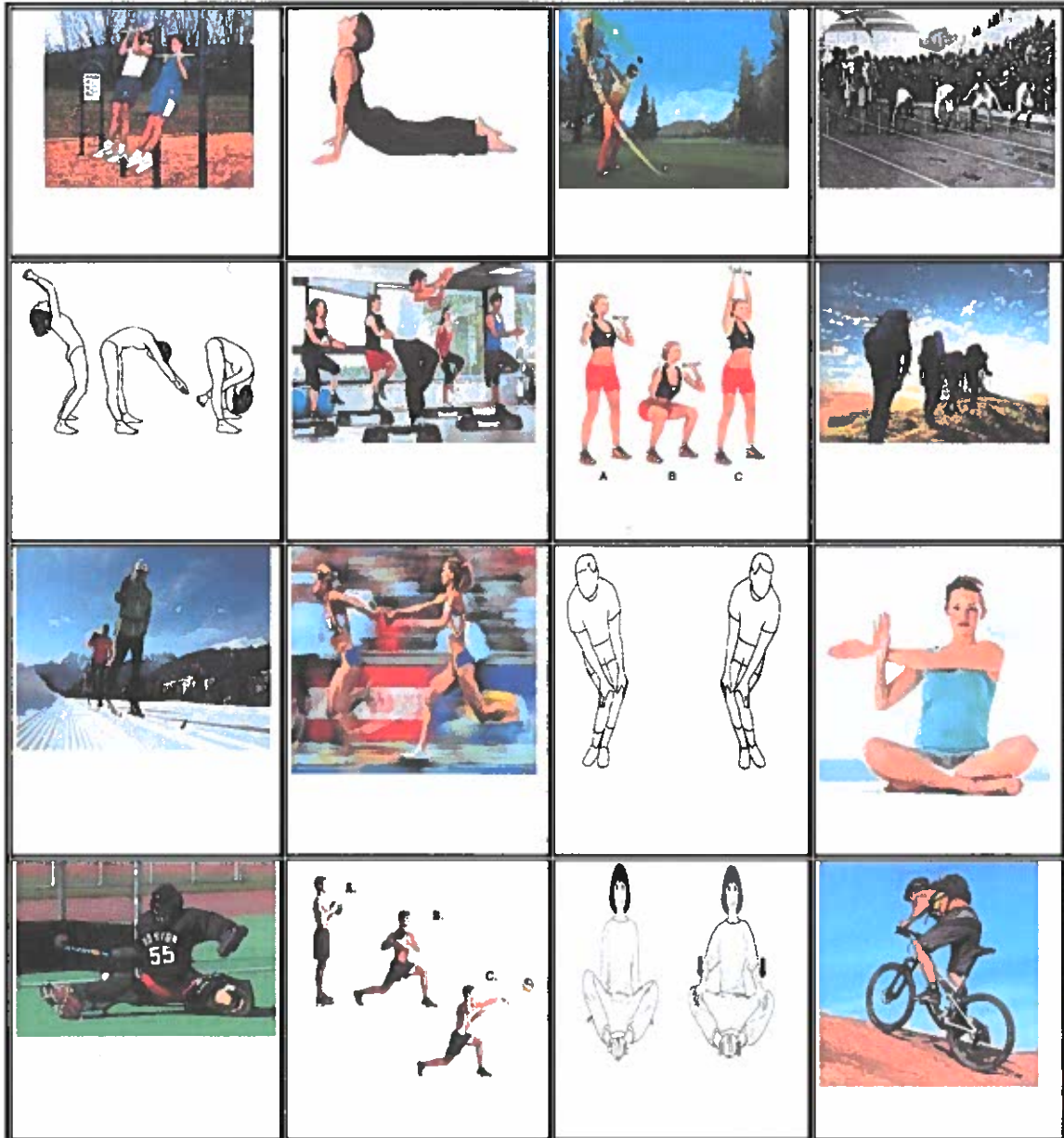

Write or draw one stamina exercise, one strength exercise, one flexibility exercise and one speed exercise (think about different examples than those which we have seen in this notebook).

Name and surnames: _____
 Class: _____ Qualification: _____

Fitness assessment II

Name: _____ Group: 1º _

WARM UP

EXERCISE	ACTIVATED SYSTEM
Continuous race 3'	
Joint mobility exercises	
Muscle elasticity exercises	
Squats	
Sit ups	
Push ups	

PHYSICAL FITNESS:

- 1) Continuous race 5'.

Physical fitness worked: _____

- 2) Passes with the basket ball.

Physical fitness worked: _____

- 3) Sit ups:

Physical fitness worked: _____

- 4) Jump (feet have to be together):

Physical fitness worked: _____

- 5) Relay race:

Physical fitness worked: _____

- 6)

Flexibility exercises: write for each exercise which muscle is being worked



Muscle

- 7) Lay-ups:

Physical fitness worked: _____



- 8) Basketball game. Which components of physical fitness do we need when we play basketball? Write one example for each of them

Physical condition tests

NAME AND SURNAME:

COURSE AND GROUP:

QUALIFICATION

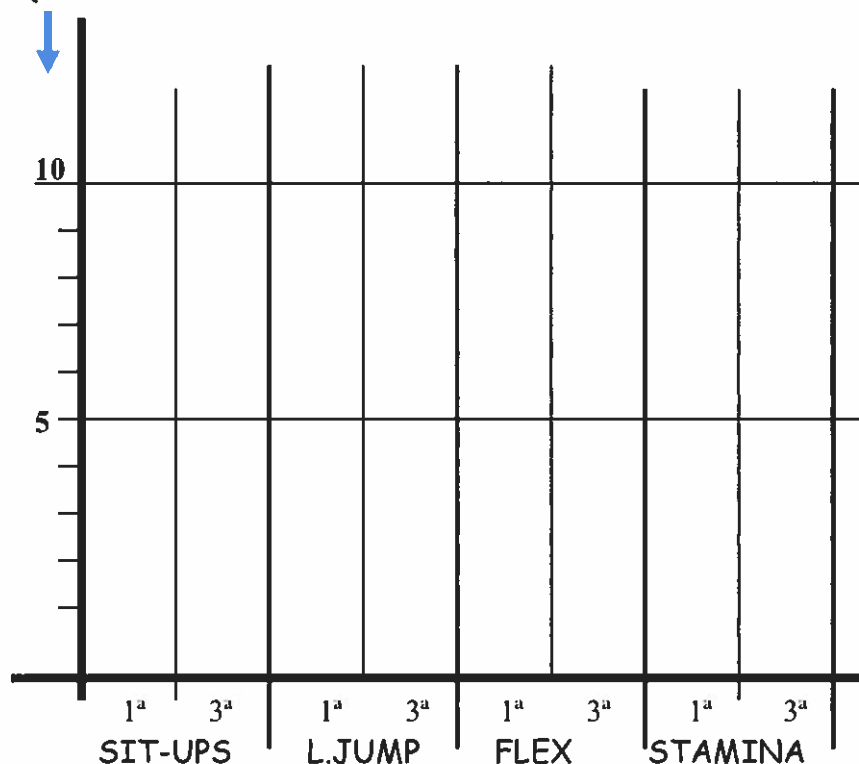

1st TERM

Report

Sit-ups		Long jump		Flexibility		Stamina	

Test Ruffier- Dickson:

Average mark

3rd TERM

Report

Sit-ups		Long jump		Flexibility		Stamina	

Test Ruffier- Dickson:

Average mark



First aid is the assistance given to any person suffering a sudden illness or injury, with care provided to preserve life, prevent the condition from worsening, and/or promote recovery.

1.- Difference between urgency and emergency:

In an emergency there is immediate threat to life or health (it requires immediate attention), whereas in urgency there is no immediate danger. However, if not taken care of in a short period of time, then the situation may turn into an emergency.

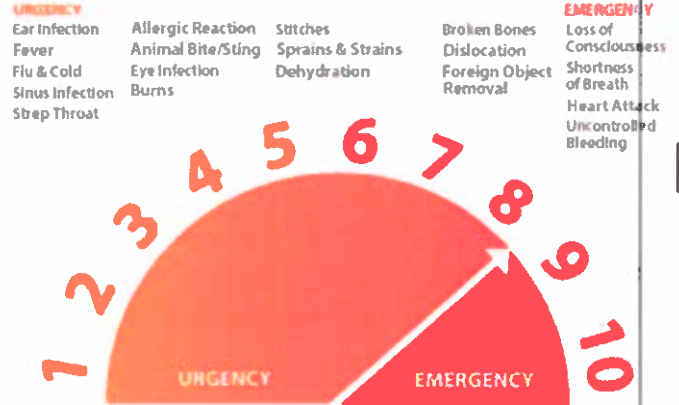

2.- Steps in an emergency:

- To protect
- To alert
- To help

TO PROTECT:

We have to protect both the victim and ourselves by making sure that a similar accident doesn't happen again. We need to be sure that nobody is in danger, and we have to protect the place of the accident.

We should not move the injured, unless their lives are in danger. If we have to move the injured, it must be done in the following ways:



TO DRAG BY THE ANKLES (IF THE FLOOR IS FLAT)

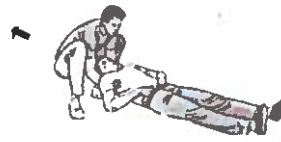

TO DRAG BY THE ARMPITS (IF THE FLOOR IS NOT FLAT)

TO ALERT:

Notify the accident to the emergency services. Call to 1 – 1 – 2 (we can use it in all European Union). We have to give the following information:

- ✗ Our name and our telephone number.
- ✗ What has happened.
- ✗ Where did it happen.
- ✗ What state is the injured person:









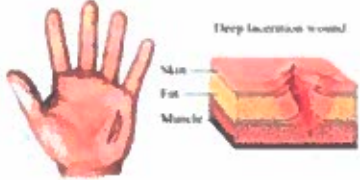

Do you know the European emergency number - 112?

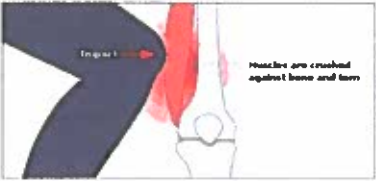

- @ Are they conscious or unconscious?
- @ Are they breathing?
- @ Is the heart beating?
- @ What is their body temperature?
- @ Besides, we must report whatever unusual things we can see (maybe they are bleeding, or have a broken bone...).

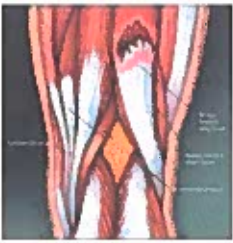
TO HELP: to give the person the attention they need. We need to know what the person needs, and how to do it properly. Otherwise, we need to look for help.

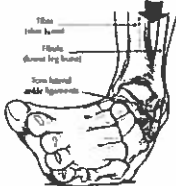
SOME INJURIES

Injury	Symptoms	Action
<p>Wound An injury to living tissue caused by a cut, blow, or other impact, typically one in which the skin is cut or broken.</p>	<ul style="list-style-type: none"> • Pain • Hemorrhage • Possible infection/inflammation • Skin irritation 	<ul style="list-style-type: none"> • Clean the wound with soap and water • Disinfect with an antiseptic (peroxide or mercromina) • Cover the wound with gauze 
<p>Contusion (bruise) Because of a hit, a region of injured tissue or skin in which blood capillaries have been ruptured; a bruise.</p>	<ul style="list-style-type: none"> • Severe pain • Inflammation and bruises 	<ul style="list-style-type: none"> • Remove clothes if pressing on the injury • Applying ice (no more than 20' three or four times daily the first three days) 
<p>Cramp A painful, involuntary contraction of a muscle typically caused by fatigue or strain</p>	<ul style="list-style-type: none"> • The muscle contracts involuntarily, causing severe pain in the affected area 	<ul style="list-style-type: none"> • Suspend physical activity you are doing • Massage the muscle until it relax • After relaxing the muscle, do some static stretching 
<p>Strain (or pulled muscle – colloquially-) Injury in which muscle fibers tear as a result of overstretching.</p>	<ul style="list-style-type: none"> • Violent feeling on a muscle. • Pain in the area, which increases when contracting the muscle. • Inability to move it • Inflammation of the area 	<ul style="list-style-type: none"> • Rest • Apply ice no more than 20 minutes (don't apply ice directly to the skin) • Use compressive bandage 
<p>Sprain The result of twist or loosening of a joint.</p>	<ul style="list-style-type: none"> • Inability to move the joint • Inflammation 	<ul style="list-style-type: none"> • Applying ice (15 – 20') • Apply an anti-inflammatory • Rest • Compressive bandage 

First aid assessment

1. What is an emergency?
2. What steps should we follow in an emergency?
3. What does it mean "to protect"?
4. What should we say when we phone 112?
5. Write five countries in which we can call 112.
6. How can we know if the victim is conscious or unconscious?
7. How can we know if the victim is breathing?
8. How can we know if the victim's heart is beating?
9. How do we know the person's body temperature?
10. What does it mean "to help"?
11. Write the name of three injuries in which applying ice is a good idea.
12. Can we keep doing sport after a strain? (explain why).
13. Can we keep doing sport after a cramp? (explain why).
14. What can be broken from a sprain?
15. How do we have to apply ice?
16. Is it a good idea to stretch after a strain? (explain why)
17. What is the difference between a wound and a contusion?

Name and surname:

Group:

Qualification:

1.- What is posture?

It is an attitude that presents a person in static standing, the usual position of our body during the day. Good attitude is one in which each body segment is close to its mechanical balance; what does it mean?: it means that we are able to move all our body without any problem. If our posture is incorrect it can cause discomfort and strain.

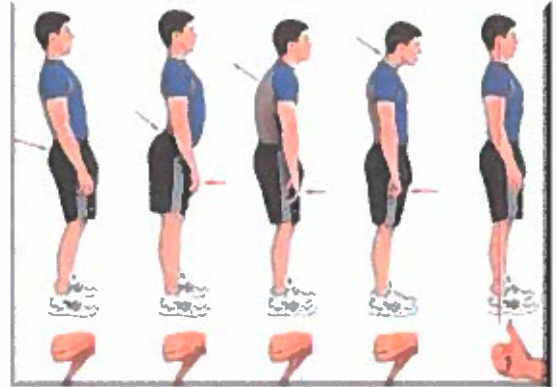

2.- What can make us to suffer pain in our spine? (in the short and in the long term)

- To remain in the same position for a long period (standing, sitting or lying down).
- To adopt certain positions that increases their physiological curves.
- To make great efforts.
- To make the same small effort many times.
- To make sudden movements or adopt a very awkward posture.

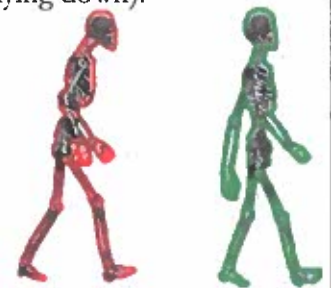

3.- What do we have to do to avoid discomfort, pain or strain?

We should combine static postures with moments of activity, avoiding prolonged sitting (as watching TV for long every day, for example). To make frequent and daily exercise is always an excellent choice.

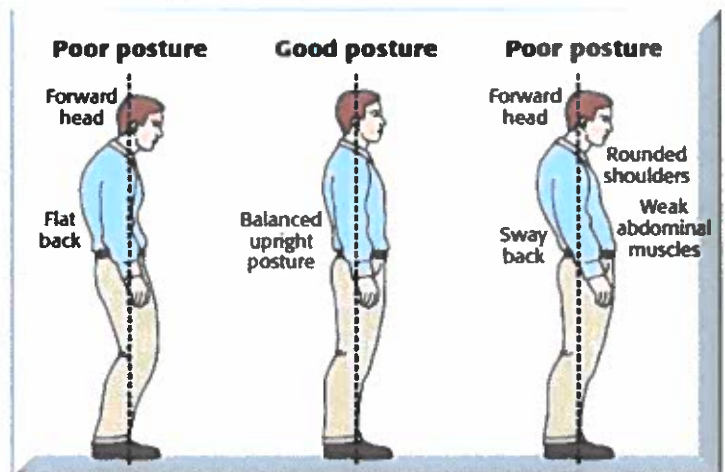
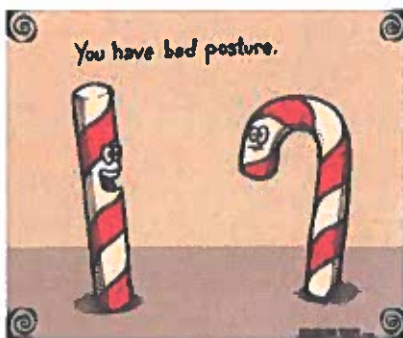

4.- What is a right posture?

2.1.- **Standing:** weight equally distributed, and back straight (even the neck). Laterally, standing before the mirror the head should be in line with your shoulders, hips and ankles.



2.2.- **Sitting:** back upright and aligned, body weight divided, heels and toes resting on the floor (if your feet do not reach the ground, put something to support them), knees bent to 90°, back firmly supported against the back of the chair (if necessary use a pillow or rolled towel to the lower back). If possible, use an adjustable chair and sit as far back as possible, supporting the spine firmly against the back.



2.3.- At the computer: the keyboard and the monitor must be in front of us (to avoid having to turn your torso or head); screen at eye level, shoulders down and elbows close to body and bent 90° (range 70 to 110°), forearms parallel to floor resting on arm support, back support for curve in spine and feet flat on floor.

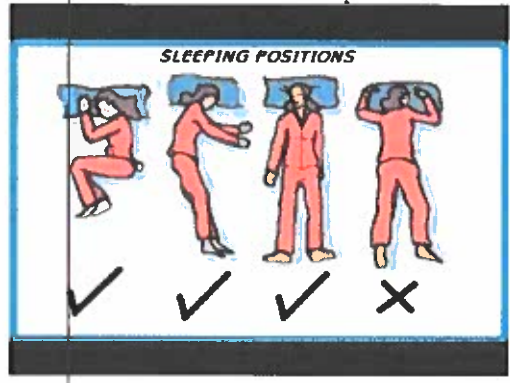
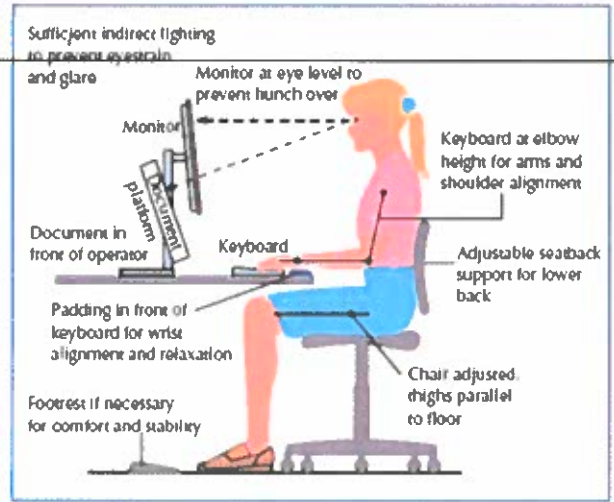

2.4.- Lying: we are in this position many times throughout our lives because we need to sleep to recover. So we need to do it properly, in order to having a good and nice rest. Some tips are the following ones:

➤ **Good positions:** sleeping on your side to align your head, neck and spine; or in a fetal position; or on your back with your knees slightly bent. Avoid thick pillows.

➤ **What to avoid:** sleeping face down is not suitable because it modifies the lumbar curvature, it would provoke pain on the neck and can create troubles to our breathe in the long term.

2.5.- Lifting a weight: never flex your back. Bend your knees and keep your back straight (to rise the weight, power from the lift comes from your legs, not from your back). Bring the load as possible to the body, without raising it above the chest. Avoid twisting when lifting objects.

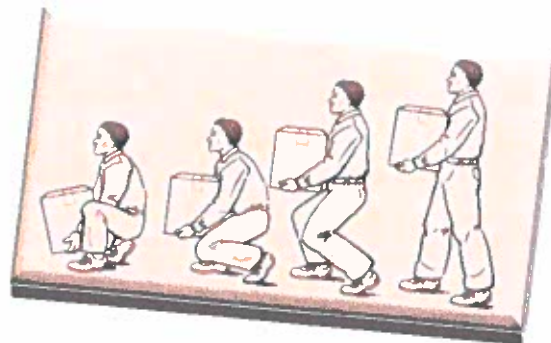
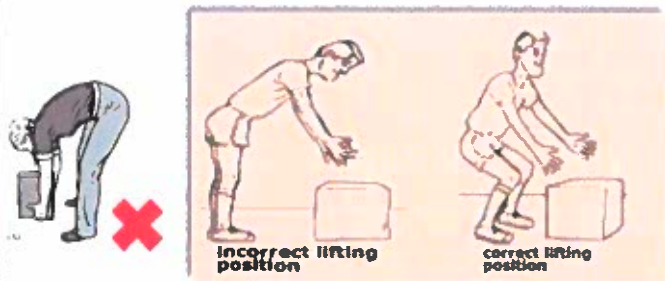

2.6.- Carrying a backpack: first, avoid it being too heavy. The weight must be distributed between the two shoulders (no carry over one shoulder!). The school backpack should be somewhat stiff, if possible with an anatomical padding in the area where it rests on the back, and it must be close to the body. The weight should be evenly distributed throughout the bag.

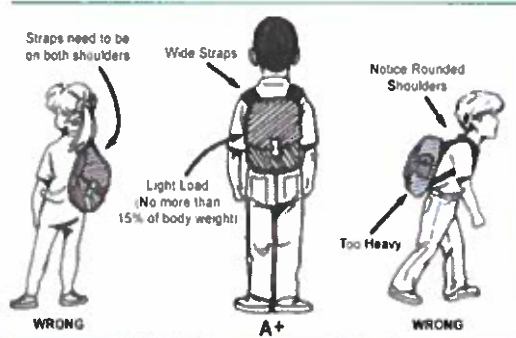
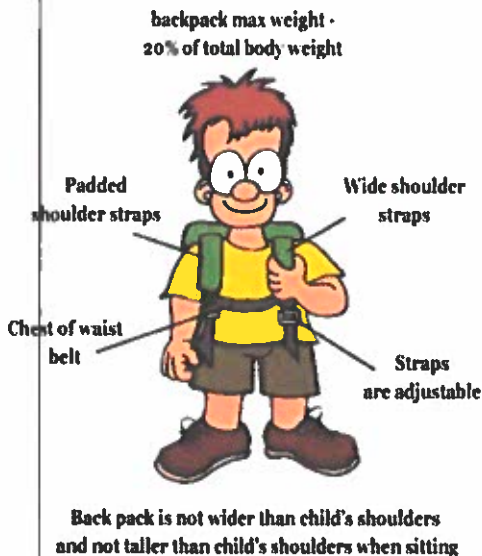

2.7.- Returning from the market with the purchase: weight distributed evenly between both arms



Posture assessment

1.- Write an example for each of the following actions which could create pain in the back:

ACTION	EXAMPLE
To remain for a long period of time in the same position, (standing, sitting or lying).	
To adopt certain positions that increase the physiological curves of the back.	
To make great efforts (which are damaged to the back).	
To make the same small effort many times.	
To make sudden movements.	
To adopt very awkward postures.	

2.- Here you have fourteen drawings. Put a cross next to those which are incorrect:



3.- Explain why the posture of the third man is incorrect in these categories:



Feet:

Knees:

Back (write two reasons):

Neck:

4.- Explain which of the following jobs /activities are painful for the back if we do them for many hours (and why):



1.- A bit of History:

The origin of Badminton took place in the 18th century in India, where it was known as "Poona". This game came to Europe about 1873 thanks to some British officers who learned there this sport. The name of Badminton comes from the place where it was most practiced in those years, the "Badminton House", a country house located in Gloucestershire, England. Other important dates are as follows:



- ▶ 1877: first written rules of Badminton.
- ▶ 1893: creation of the Badminton Association of England.
- ▶ 1934: creation of the International Badminton Federation (IBF).
- ▶ 1949: first international competition.
- ▶ 1972: demonstration sport in the Munich Olympic Games.
- ▶ 1977: first official World Championship.
- ▶ 1986: creation of the Spanish Badminton Federation.
- ▶ 1992: official sport in the Barcelona Olympic Games.



2.- Basic Badminton rules:

The aim of Badminton is to pass the shuttlecock over the net by hitting it with the racket, so that it lands inside the opponent's half of the court. You can also gain a point if the opponent fails in this objective.

The match ends when a player wins two games. To win a game, a player has to score 21 points. Nevertheless, if the score is 20 – 20 the match has to continue until one player has two more points than the other. If this doesn't happen until 29 – 29, then the player who wins the 30th point wins the game.

The player who serves is the player who won the previous point; if their score is even (2, 4, 6...) then the serve is from the right side of the court; if their score is odd (1, 3, 5...) the serve has to be taken from the left side of the court.

When serving there is no double fault, and the shuttlecock is not allowed to touch the net

The line is part of the court so, if the shuttlecock falls onto the line, it is not out, it is inside the court).

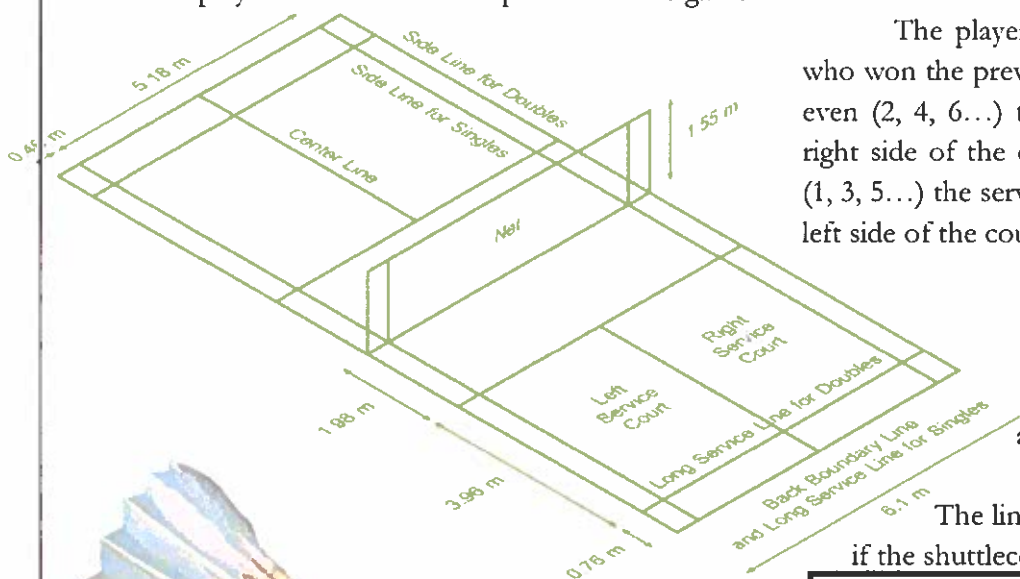

There are official competitions for singles and doubles (both for men and women), and mixed doubles (there are a man and a woman on each team). You can see in this drawing how the court is set up in a singles and doubles match; notice the different serving areas.

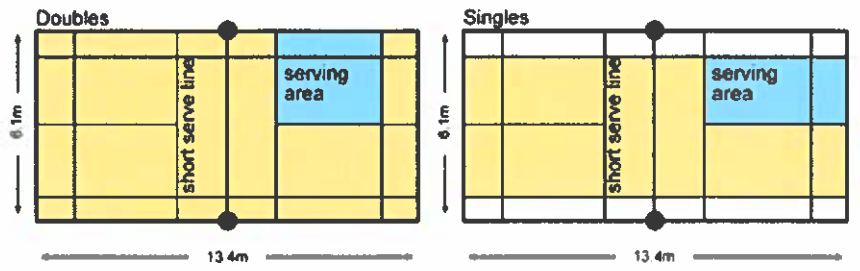

In the serve, the hand which holds the racket has to be above the head of the racket

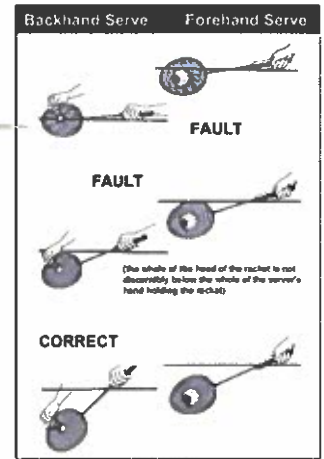

3.- How to hold the badminton racket:

Fingers surrounding the handle of the racket (little finger surrounds the end, and thumb is between the index finger and middle finger). The V between thumb and index finger is on the vertex of the racket

4.- Main Badminton shots:

1. High clear (defensive)
2. Fast clear (offensive).
3. Drive
4. Smash
5. Drop
6. Net drop

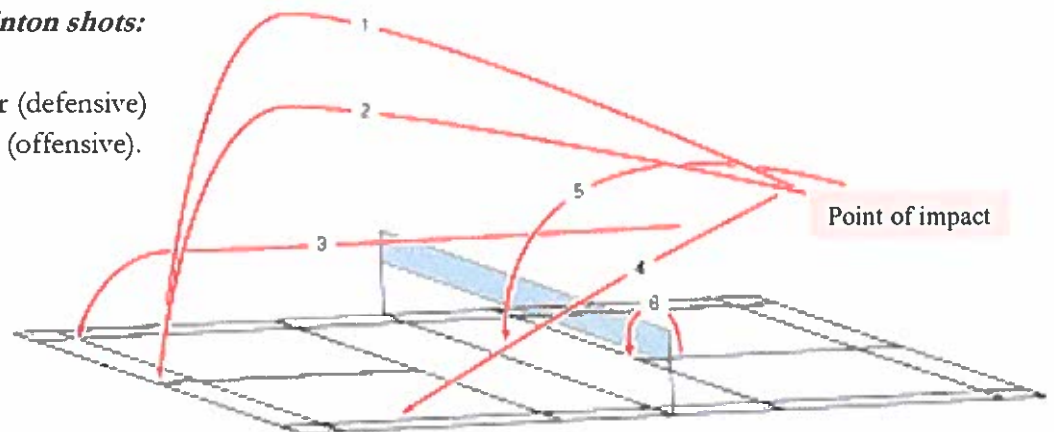

Spanish Badminton Federation

Web site: www.badminton.es

Avda de Filipinas 26. 28003. Madrid. Telephone number: 91 542 83 84.

Madrid Badminton Federation

Web site: www.fembad.com

Avda de Salas de los Infantes 1. 28034. Madrid. Telephone number: 91 358 22 20

Badminton assessment

1. What is the minimum number of games in a match?
2. What is the maximum number of games in a match?
3. What is the minimum number of points in a game?
4. What is the maximum number of points in a game?
5. What happens if the shuttlecock touches the net during the serve?
6. What happens if the shuttlecock touches the net at any time apart from the serve?
7. Say whether the following sentences are true or false:
 - ❑ In a game the winner always has to have at least two more points than the opponent.
 - ❑ In a doubles match the playing court is bigger than in a singles match.
 - ❑ It is not possible to make a smash in the serve.
 - ❑ It is not possible to make a drop in the serve.
 - ❑ The lines are part of the playing court.
8. Draw the serving area in a singles match when the score is 1 -1.
9. Draw the serving area in a doubles match when the score is 2 -2.
10. In which two main situations can you gain a point?

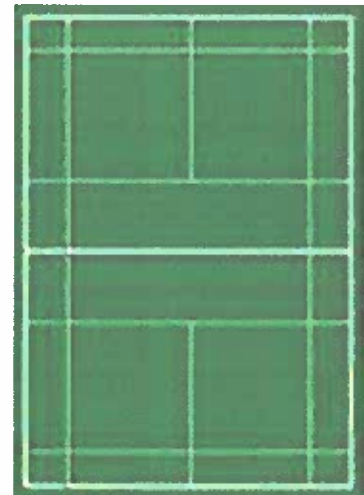

Name and surname:

Course and group:

1.- A bit of History:

Even though, at the end of the 19th century, there were many different games with some similarities to handball, the first rules of this sport were written in 1919. In those days every team had 11 players, and the playing field was a football field. In 1936 Handball was chosen as one of the Olympic Sports (in Berlin). Despite the heavy rain, 100.000 spectators were at the stadium. The I.H.F. (International Handball Federation) was created in 1946, after the World War II, and the official rules of the game are assumed by its different countries. Since 1951 the number of players on each team is seven.



2.- Basic Handball rules:

- ◆ **Players:** Handball is a sport played by two teams of seven players (six court players and one goalkeeper) whose aim is to score as many goals as possible. Substitutions are allowed at any time, with no limitations.
- ◆ **Duration of the game:** each match lasts 60 minutes, which is divided into two periods of 30 minutes. Between them there is a break of ten minutes.
- ◆ **Playing field and field areas:** only the goalkeeper is allowed inside the goal area, who can also act as a court player. Court players can't enter the goal area, but it is possible to touch the ball in the air above the area (if the player jumps from outside of the area).

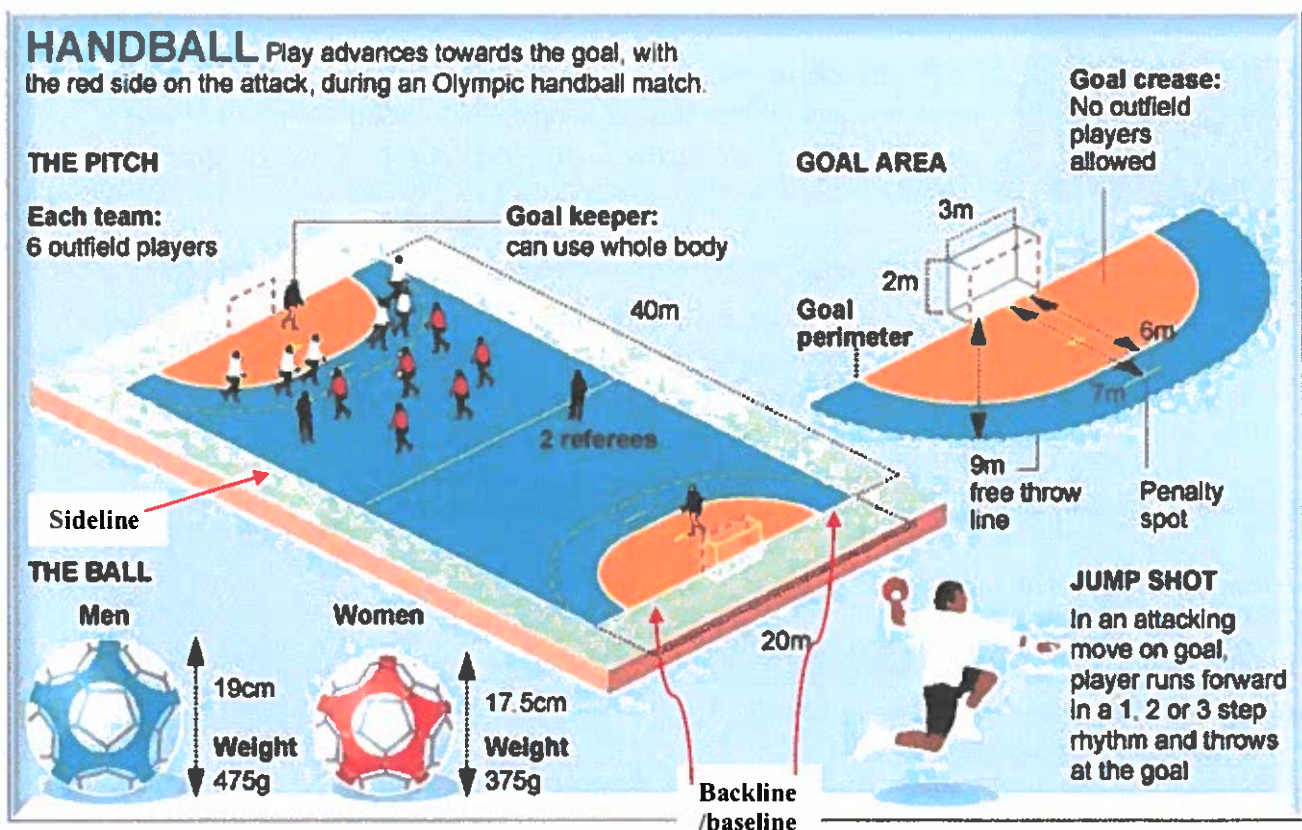

- ◆ **How to play the ball:** even though you can touch the ball with all your body above the knees. The ball is always played with the hands, and every player has to bounce it when walking or running. But, before and after bouncing the ball, a player is allowed to take three steps. So, to sum up, when a player takes the ball they can take three steps, bounce the ball (as many steps as they wish) and take another three steps.



If a player, after bouncing the ball, picks it up, then they can take three steps and pass the ball or shot at goal, but bounce the ball again is not allowed (it is foul). Neither is allowed to hold the ball more than three seconds.

- ◆ **Goalkeeper:** in the goal area, the goalkeeper can touch the ball defensively with any body part. Outside the area, the goalkeeper can act as a court player, but leaving the area with the ball in his hands is not allowed (he needs first to pass the ball, and then leave the area).



If after a shot the goalkeeper clears the ball by the outer goal line then the possession of the ball is to the goalkeeper. If the ball goes by the sideline then its possession is for the opponents.

- ◆ **Defenders:** these players have to stay (always!) between the ball and the goal. Without hitting or pushing, body contact is allowed and, for example, you can block the way of an opponent with your body. Taking or hitting the ball, when it is held by an opponent, is not allowed. When a defender clears the ball, either by the outer line or by the side line then the ball is for the opposing team.



- ◆ **Attackers:** when a team has possession of the ball, this must try to score a goal. If this doesn't happen, and a team is trying to waste time, the referees can declare passive play (free throw for the opposite team).

- ◆ **Fouls:**

- ✗ Free throw: for a minor foul. If this occurs between the goal area line and the 9 meter line the throw take place from the nearest point of this 9 meter line. The thrower can pass the ball or make a shot, but can't jump and has to keep one foot in contact with the floor.
- ✗ Seven meter throw: when a defender fouls in a clear scoring chance.

Spanish Handball Federation

Web site: www.rfcbm.es

C/Ferraz 16, 2º. 28008. Madrid. Telephone number: 91 548 35 58.

Madrid Handball Federation

Web site: www.fmbalonnano.com

Avda de Salas de los Infantes 1, planta 6. 28034. Madrid. Telephone number: 91 64 63 47



Handball assessment

Name and surname: _____

_____ Group: _____

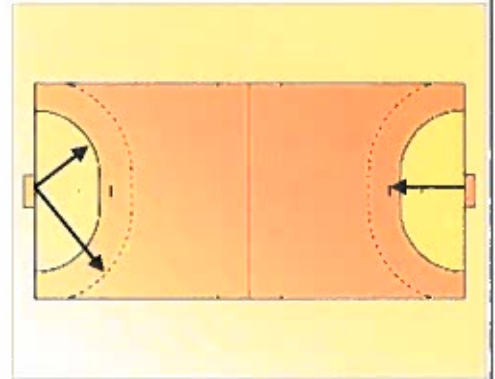

1. Paint the goal area in blue.
2. Paint in red the line from which the free throw takes place (if the fault took place near the goal area).
3. Point to where the seven meters throw is.
4. Point where are the following lines: side line, back line (base line), goal line.
5. Write the distance of these lines in the court
6. Say whether the following sentences are true or false:
 - All the players can only touch the ball with their hands.
 - No player can stay inside the goal area.
 - There are seven players on each team (inside the court).
 - A handball match lasts one hour.
 - Sometimes it is possible to touch the ball above the goal area.
 - Walking four steps with the ball without bouncing it is allowed.
 - It is a fault not trying to score a goal.
 - It is a fault to touch the ball with your head.
 - A player can bounce the ball as many times as they wish.
 - A player can take the ball, bounce it, take the ball again, and bounce it again, as many times as he wishes.
 - The goalkeeper can score a goal throwing the ball with their foot.
 - The goalkeeper can stay in the goal area, take the ball, bounce it until reaching the opposite area, and attempt to score from there.
 - Is not allowed to jump during a seven meter throw.
7. How many substitutions are allowed in a handball match?
8. In the picture at the bottom of this page, what kind of throw is going to happen?
9. Point to who is the goalkeeper, who is the defender, who is the attacker and who is the referee.

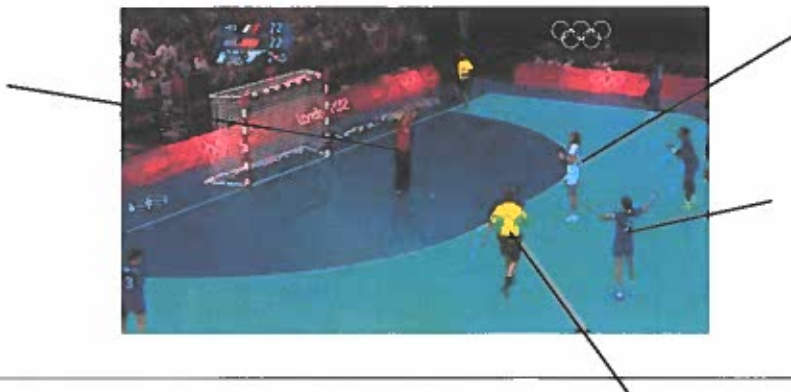

1.- What is orienteering?

It is knowing where we are in relationship to the four cardinal points: north, south, east and west.

There are, also, secondary cardinal points: north east (NE), north west (NW), south east (SE) and south west (SW).

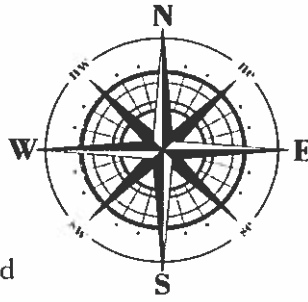

Orienteering as a sport is a race on the nature in which each runner has a compass and a map of the area. In this map there are pointed many points, and every participant has to go to each of those points.

2.- How can we orient ourselves?

> With natural elements:

There are many that we can use. Some of them are as follows: the sun, the polar star, snowdrifts, tree moss, felled tree rings, the migration of birds, nesting trees, the phases of the moon.

> With artificial elements: map, compass and electronic devices (GPS, etc).

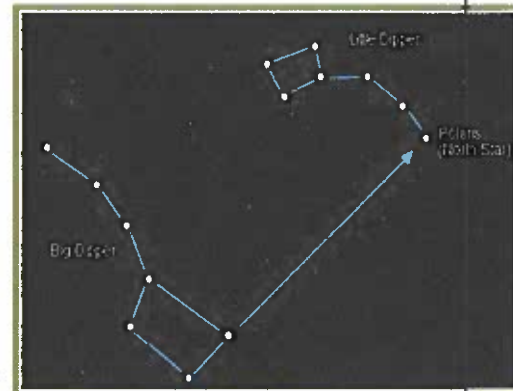

a) NATURAL ELEMENTS

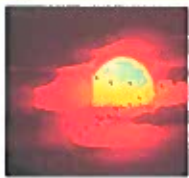

The sun: every day, it rises in the east, and sets in the west (through southern).

The polar star: Its position indicates where north is.



Snowdrifts: in the mountains, the places where there are more snow shows us in which direction north is.

Moss: places where there is more moss shows us where north is.



Felled tree rings: the area where the rings are closer to each other points to the north.



The migration of birds: they fly to the south in the winter, and to the north in the spring.



Nesting trees: they usually have a south orientation



The moon: depending on the phase and the time. Look at the schedule.



TIME	CRESCENT MOON	FULL MOON	WANING MOON
18:00	S	E	N
21:00	SW	SE	NE
24:00	W	S	E
3:00	NW	SW	SE
6:00	N	W	S



b) ARTIFICIAL ELEMENTS

Even though there are many different artificial elements (a compass used to be the most commonly used, but nowadays we have GPS in cars, or specific mobile services and applications on some mobile phones) for our course this year we will only be using a map.



b.1.- What is a map?

A map is a scale representation of reality, which means that the distances on a map and distances in the real world are proportional.

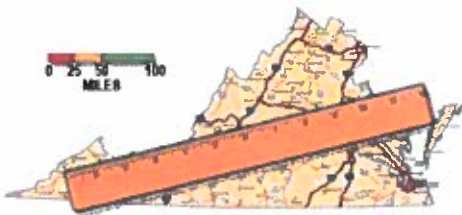

For example, if there are forty six kilometers between Madrid and El molar, and there are ninety two kilometers between Madrid and Somosierra, then El Molar is right in the middle of this route. Then, if we view a map of all this area, and on the map the distance between

A map uses symbols, signs and drawings to express things and elements that are in the real world. If we don't know what these symbols mean, we need to look at the Map Key.

Map Key: explains the symbols, signs and drawings that we are going to find on the map. To help us, as a rule, every color has a different meaning:

- 🌿 Green: vegetation
- 🏔️ Brown: mountains.
- 🌞 Yellow: open ground with good visibility.
- 💧 Blue: water.
- 🏠 Black: constructions made by humans (such as roads, buildings, train tracks...).
- 📍 Red: overprinted symbols of an orienteering courses (starting point, control points, control numbers, finish point).

(The darker the colors are on the map, the higher the mountain, or the deeper the water, or the thicker the vegetation).

Trail Head	Gravel Wood Chip Trail	Civic Building
Traffic Signal	Local Trail	Parks
Transit Park & Ride Lot	Regional Trail	Parks outside City limits
Sidewalk	Creek	Golf Course
On Road Bike Route	Lake/Pond	School/Community Center

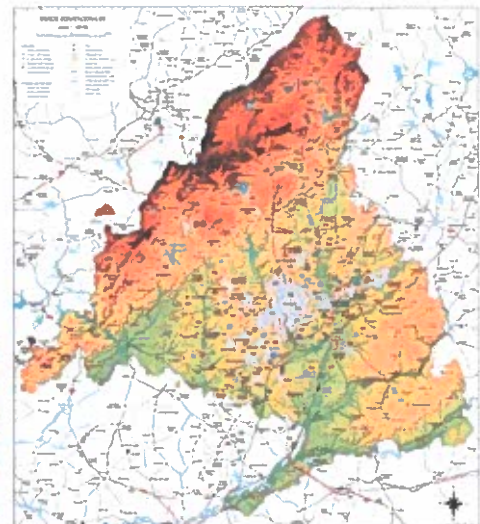

b.2.- How to use a map?

To use a map we need to know both where the real north is (as we saw on the previous page), and where the north is on our map. This one (the north on our map) is usually the top of the page but, in case it isn't there, there is always a sign which shows us where it is. Here are some of these signs:

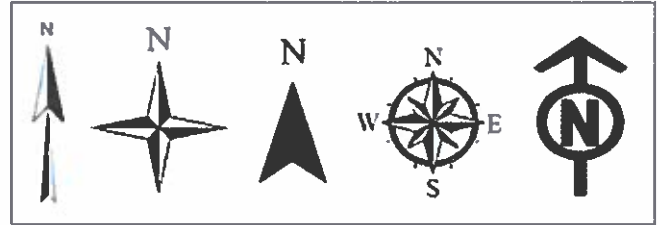

Therefore, when we know where both north in the real world and the north on the map are, what we have to do then is put both of them together (we should point the north on our map towards the real north).

From this moment on, no matter what our direction is, the north of our map must be pointing north in reality. So, if we are walking east, at the top of our map must be the east of our map, and the north of our map would be on the left side. In this way, we are able to see reality as we see it on the map (all in the same position).

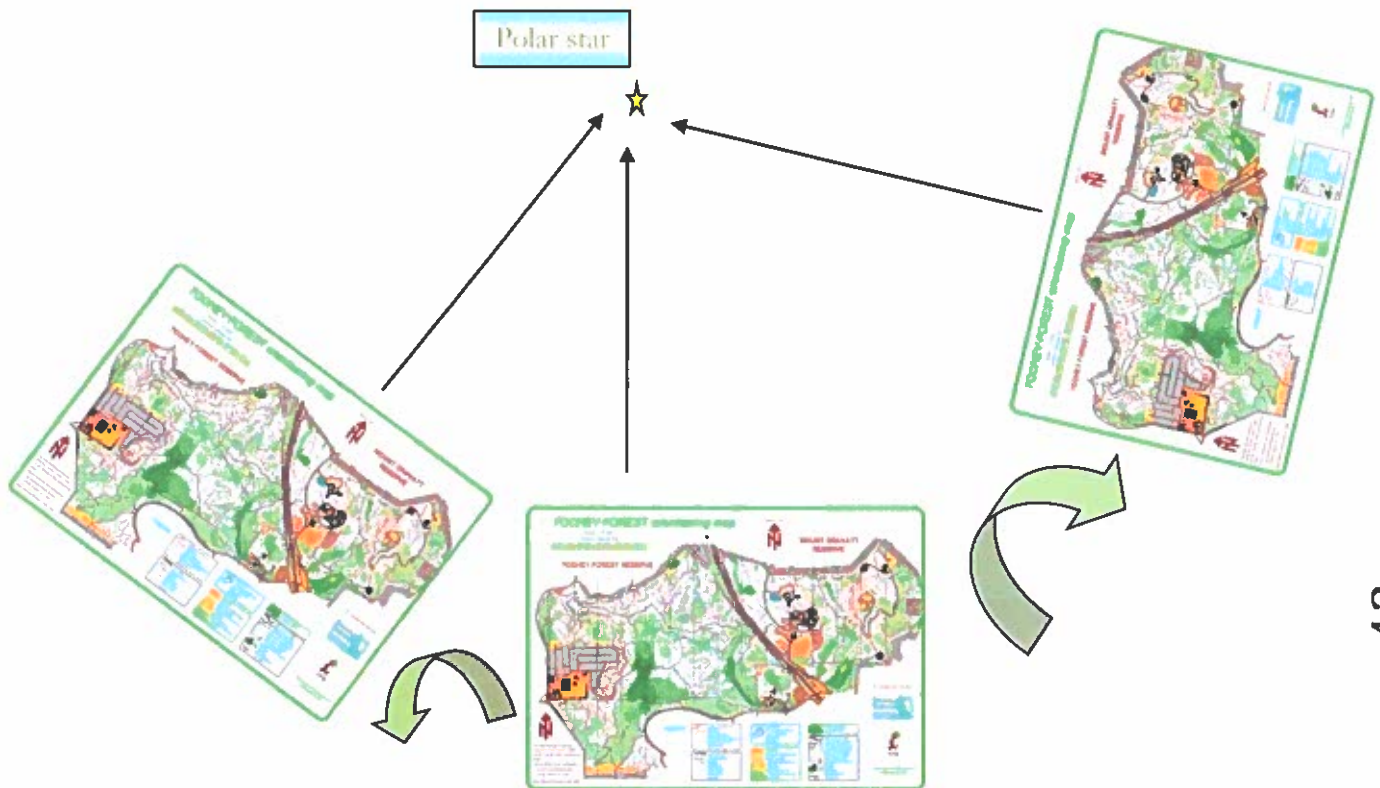

Orienteering assessment

1.- Write where the four cardinal points and secondary points are on the wind rose:



2.- How can we know what the symbols on a map mean?

3.- Write the meaning

of the following colors on a map:

Blue:

Black:

Green:

Brown:

Yellow:

4.- Answer each of these questions:



You are looking at this nest. What cardinal point are you looking at?



Winter is coming. To which cardinal point are these birds flying to?



Write on this picture where north, south, east and west are.



Which star is the north star?



It's midnight. Which cardinal point are we looking at?



There is no snow on the other side of the mountain. Which cardinal point are we looking at?

It's getting dark, and we are looking at the sun. Which cardinal point is behind us?



If we are walking in the woods and we see this tree, which cardinal point are we looking at?

Name and surnames: _____ Class group: _____

Hiking is an outdoor activity that consists of walking along paths in beautiful, natural environments.

1.- Objectives:

- 📖 Perform outdoor activities in a natural environment.
- 📖 Recognize the material needed for its realization (equipment, clothing and food).
- 📖 Become aware of the impact of certain activities when they are practiced in nature: respect the environment.
- 📖 Learn about one more activity that you can enjoy in your leisure time.



2.- Aspects to consider:

- 🌟 Time available; duration of activity, start and finish points, approximate arrival.
- 🌟 Location: where will the route be (eg Sierra de Guadarrama).
- 🌟 Route: from which starting point, through which trails or paths, how far we will go.
- 🌟 Basic information and documentation: topographic map of the area. We also need to have information of the area: if it is flat, hilly, main characteristics of the weather and wildlife, where are areas of drinking water ...



3.- Basic standards of environmental conservation:

- No littering (including biodegradable).
- Do not make noise or shout (it frightens and disturbs the animals).
- Do not collect or destroy plants, rocks or animals (it is essential to learn to make good use of the environment: our presence should influence it as little as possible).

4.- Other advices:

- ⚡ Do not ever loose contact with colleagues.
- ⚡ Take your charged mobile phone with you.

5.- Material needed:

Where to carry it: small backpack (try not to carry too much weight).

Food: sandwiches, fruit, nuts ... (to prevent excessive weight, bring food that does not require a lunch box, dishes, cutlery, etc).

Drinking: water bottle, plastic bottle or something similar (do not carry glass objects) filled with water (it's better than soft drinks: they make you thirsty). During the activity you should drink water even if you are not thirsty: the sensation of thirst is not manifested until the body has lost a lot of water).

Clothing and footwear: hiking boots (used, comfortable, strong, with a sole which provides a good grip; if you haven't, then you can use running shoes), spare socks, cotton shirt, sunglasses, hat.

Other: sunscreen, trash bags (it is very important not to leave any waste on the mountain), camera, first aid kit



NAME AND SURNAME:

CLASS GROUP:

THE PRECIOUS STONE (A STORY)

It was winter. Birds were migrating to the north. It was already the second day in which he remained alone in the mountains, and the man remembered well the cause of his adventure.

He had been collecting some lovely flowers and, following a beautiful fox until far away from the path, he lost touch with his friends. When he wanted to return, he failed to find the way. He wanted to call, but his phone had been out of battery since the beginning of the hiking.

He leaned back over the side of a tree covered with moss and looked ahead to what he thought would be the south. His sandals were broken, and his feet hurt. He had some sunburn on his head because despite having a bald head he still refused to use any kind of hat. He almost hurt himself when his crystal bottle broke inside his big backpack, which he left abandoned in the middle of the path afterwards.

He was thirsty, but he had finished his last can of coke last night, he hadn't brought water and he didn't know where he could find it anymore. However, lentils had been an excellent dinner. As he had no sleeping bag, he slept on the floor. He had a dream. He dreamed of speaking with a wise man, tall, with a red beard and a yellow bag. In his dream, this man had a precious stone which he gave to him, making him rich forever. But it had only been a beautiful dream.

At dawn, he looked west to see how the sun rose into the sky, and tried to work out where he could be. Of course, it was impossible, because he had no map, and he didn't know anything about the area.

Right at that moment he saw a man, the same man which he had dreamed about. He wore a yellow bag and his beard was red. He ran up to the wise man and said, "the stone, the stone, give me the precious stone!".

"What precious stone?", asked the wise man.

"The other night I had a dream", said the man, "a dream in which you gave me a precious stone that would make me rich forever."

The wise man looked inside his bag and took out the stone he had. "Are you talking about this?", he said, as he handed the stone to the man. "I found it on a forest path several days ago. Of course you can have it if that is what you want."

The man was astonished. It was a diamond! Perhaps the biggest diamond in the world, and it was as big as a man's hand.

The man took the diamond and started happily running and jumping, until he suddenly stopped and began to think. After a few minutes he returned to the wise man and told him: "I don't want this, I want the kind of wealth that allowed you to let go of this Diamond!"

FIRST PART OF THE TEXT

- ☒ There are fifteen things that the man did wrong when preparing the hiking or during it. What are those things?
- ☒ There are three mistakes in the text about orienteering. What are they?

SECOND PART OF THE TEXT

- ☒ (Optional, not mandatory): What does the man finally begin to appreciate?

Gymnastics and acrogym

1.- Basic position for the forward roll/somersault:

- Lying flat on your back, keep your back rounded, and hold your knees close to your chest. You have also to put your chin close to your chest
- Rock backwards and forwards with a little more power. When your feet make contact with the ground, stretch forward with your arms and attempt to stand.
- From standing, crouch down, roll back on to your shoulders and rock back to your feet.
Forward roll/somersault:
- From standing, crouch down. Place your hands on the floor in front of you, shoulder-width apart with your fingers facing forwards, while simultaneously place your chin on your chest. This will ensure that your hips are raised high enough and your spine is rounded so that you can roll on to your back.
- Bend your arms and place your back of the head on the floor, extend slightly the legs and push on the floor with your feet until the roll commences and you roll on to your back.
- Try to keep your legs straight at the beginning of the somersault, and bend them so that your knees are close to your chest and your heels are close to your gluteal.
- At the point where your feet make contact with the floor, stretch forwards with your arms so that your head and chest move over your feet. Once your body weight is in a position of balance you will be able to stand. You should avoid to put your hands on the ground as a help to stand.



2.- Backward roll/somersault:

- From standing, bend your legs to stay in a lower squat position with your back well rounded.
- Allow your body to move backwards so that your body weight falls back over your heels until your bottom makes contact with the floor.
- Roll your body backwards until your shoulders make contact with the ground. Then, move your hands quickly to a position just above your shoulders, with your fingers pointing at the way we are going, and your palms down, elbows above our hands. Your fingertips should make contact with the ground, then your palms.
- As the rolling movement takes place, put your chin on your chest and press the ground with your hands so that as little weight as possible is put on your head.
- When your shoulders make contact with the floor, push against it strongly with your hands and straight your arms. This raises the hips slightly and takes the weight off the head.
- Continue to rotate your body, still maintaining the curled position, until your feet reach the ground. The movement is finished in a squat or standing position.



3.-Handstand from crouch position:

- Crouch down and place your hands and forehead on the floor to form an equilateral triangle (see diagram). Your head should be approximately 30 cm in front of your hands and your arms bent at an angle of 90 degrees.
- Extend your legs so that your pointed toes are resting on the floor.
- By pressing with your hands, slowly move your hips over your forehead into a balanced position. Maintain the equilibrium by continually pressing with your hands.
- With more pressure you will reach a point at which you can lift your feet from the floor.
- Continue to raise your legs above your head by pressing constantly against the floor with your hands. Make sure that your back is kept straight at all times by tightening your gluteal and abdominal muscles.
- As your legs move above your shoulders you will need to take your hips back slightly to prevent yourself from falling over.

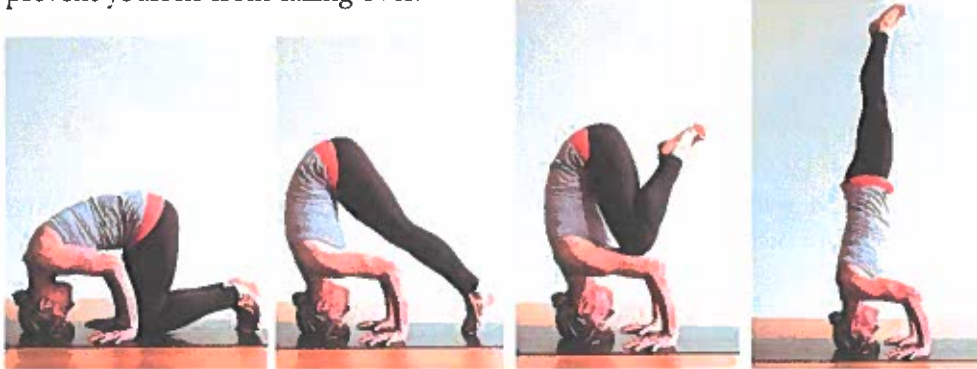
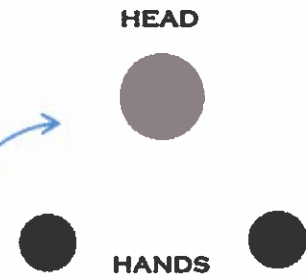

4.-Acrogym:

It is a combination of gymnastics and dancing. Working in groups, while dancing they have to do several different acrogym figures. (Sadly, we don't have enough space or mats to create a choreography).

4.1.- Roles:



- ▶ Base: they support the weight of the agile.
- ▶ Agile: they climb on top of the base, maintaining a static posture (usually).
- ▶ Assistant: they help both the base and the agile to do the figure or pyramid; also, they prevent falls.
- ▶ Observer: observes the work of the others, provides tips for improving the pyramid.



4.2.- Prevention and safety:

- ⊗ Everybody must know perfectly how an exercise must be done before putting it into practice.
- ⊗ Stop exercising and start the exercise again whenever support is not correct, or there is a risk of falling. Maintain constant communication among all members of the group.
- ⊗ Do not perform a more complicated exercise until the previous step is mastered.
- ⊗ Changing from one position to another slowly, always controlling the movement. Prevent falls.
- ⊗ Do not perform an exercise without assistance when it is needed.
- ⊗ Do not perform any exercise if you are injured or in pain.
- ⊗ Remove shoes every time a person is going to get on top of another.
- ⊗ Avoid exercise if there is a possibility of collision with objects or people (place mats away from walls, banks or other peer groups).
- ⊗ Take care where we put our weight on others.

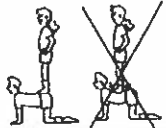
4.3.- Basic positions:

BASIC POSITION	DESCRIPTION	WHERE TO SUPPORT
<p>On all fours</p> 	<p>Hands and knees on the floor; hands under shoulders, and knees under hips in order to provide a firm basis. The back has to be straight. Don't bend your elbows.</p>	<p>We can only put our weight over our partner's hips or shoulders. To avoid injuries we should never put weight on their back.</p> 
<p>Truck</p> 	<p>Keep your abs and gluteal contracted. Shoulders should be above hands. The body has to be completely straight. Don't bend your elbows.</p>	<p>Over our partner's shoulders. If we are going to raise someone in a truck, never bend your back: keep it straight and bend your knees, take the truck by their feet and stand up.</p>

Gymnastics and acrogyim assessment

Each student must perform:

- Forward roll.
- Backward roll.
- Handstand from crouch position.
- On all fours.
- Truck.
- Two pyramids.



Rhythm and movement

Rhythm can be defined as the harmonious combination of sounds, voices or words, which include the pauses and silences necessary to be pleasing to the senses. Related to movement, rhythm is the ratio between the time of two movements.



To develop rhythm some exercises we are going to do are:

- ☀ Natural movements like walking, running or jumping, and we are going to do different types of steps and jumps.
- ☀ Mobilization of each part of the body.
- ☀ Combinations of movement and sounds.
- ☀ Adequacy of movement to music.
- ☀ Imitation of rhythms; creation of our rhythms.
- ☀ Follow a specific rhythm. Contrasts fast - slow.
- ☀ To listen to a certain rhythm, and choose a sequence of movements.
- ☀ Take an action and increase the pace, performing the same action faster and faster.
- ☀ Carry out different actions following a certain rhythm.
- ☀ Follow the same rhythmic sequence with different parts of the body.
- ☀ Move freely following a certain rhythm (clapping, a tambourine, music...).
- ☀ Circuits with different music.
- ☀ Aerobics.



Trying to achieve high goals is essential in order to recognize and accept weaknesses, then you can learn to overcome them gradually. You can always improve.

In our case, if we had not been convinced that you can always improve, my nephew had not won many trophies. I've heard Rafael say the following statement many times in front of a microphone, after winning in a final.

"What is your next goal?" Asks every journalist.

"Now I just have to keep improving. This is my next goal".

Toni Nadal. Thinking heads. First edition publish on April 2015 by Alienta editorial. Barcelona.

(Original title: Todo se puede entrenar, - available in Spanish-)

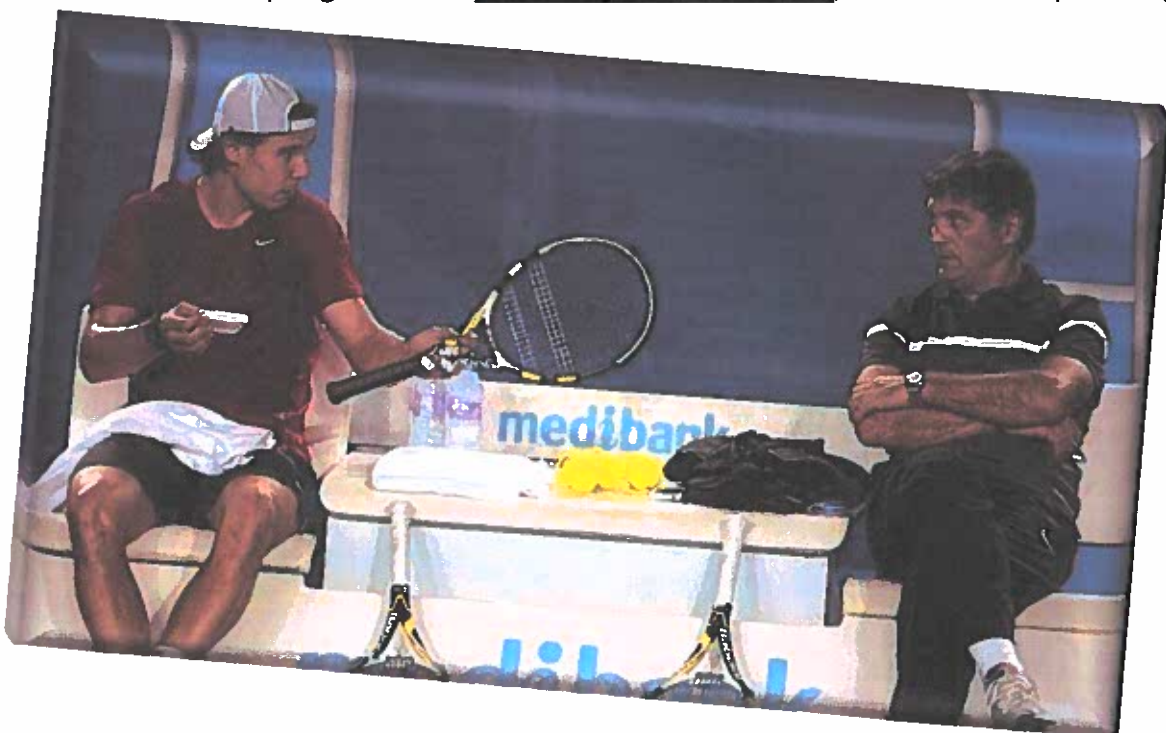

CRITERIOS DE CALIFICACIÓN DEL DEPARTAMENTO DE EDUCACIÓN FÍSICA

La calificación final será la media obtenida entre los siguientes apartados, según el porcentaje atribuido.

Evaluación de los aspectos cognitivos o conceptuales: 30%

* Pruebas teóricas (exámenes y controles). Para poder hacerse media con los restantes apartados, cada alumno ha de obtener al menos un 3,5 (si no es así, la evaluación estará suspensa al considerarse que el alumno no ha asimilado los conocimientos mínimos necesarios).

* Fichas y trabajos escritos.

Evaluación de los aspectos procedimentales: 40%

* Pruebas prácticas/ habilidades de cada Unidad Didáctica

En caso de NO realizar una prueba práctica y justificarla adecuadamente ésta se llevará a cabo con otro grupo, o bien se utilizará la hora del recreo previo acuerdo con el profesor/ a (es responsabilidad del alumno/ a la solicitud de una nueva fecha).

ALUMNOS LESIONADOS

En el caso de no poder realizar la clase o alguna prueba por prescripción médica, el profesor evaluará al alumno de todos los contenidos que estén en condiciones de realizar, con un nivel de exigencia adaptado a sus posibilidades, con ayuda del departamento de Orientación en caso necesario. En cualquier caso, los alumnos deberán: acudir a clase; realizar aquellas actividades prácticas que le sea posible realizar sin perjudicar su estado; tomar nota de los contenidos teóricos que se expongan; realizar el trabajo teórico que el profesor le solicite (tomar nota de la clase, lecturas, fichas, etc); asimismo, deben colaborar con la clase en los momentos en que se precise su ayuda (para la utilización del material, arbitraje, música, toma de tiempos, medidas, etc).

Evaluación del aspecto actitudinal: 30%

* Comportamiento, participación, interés, constancia y esfuerzo.

* Asistencia a cada sesión con la indumentaria deportiva adecuada (ropa y calzado). Cambiarse de camiseta y asearse al finalizar cada sesión.

RECUPERACIÓN DE EVALUACIONES PENDIENTES

Si se suspende alguna evaluación ésta podrá recuperarse de la siguiente forma mediante la repetición de las pruebas suspensas (caso de las pruebas prácticas o el examen escrito) o la mejora en su actitud, esfuerzo y trabajo (caso de la parte actitudinal).

RECUPERACIÓN DE MATERIAS PENDIENTES DE CURSOS ANTERIORES

Los alumnos que hallándose en 2º, 3º o 4º E.S.O. con la materia suspensa de uno o varios cursos precedentes aprueben el curso en el que se encuentran recuperarán asimismo el precedente y, por tanto, dejarán de tener la materia pendiente. Podrán asimismo recuperar dicho curso precedente si aprueban las dos primeras evaluaciones del curso en el que se hallen.

No obstante, los alumnos que tengan la materia pendiente (y no hayan aprobado las dos primeras evaluaciones del curso actual) tendrán la oportunidad de realizar un examen teórico en la última semana de abril o principios de mayo para superar los contenidos teóricos mínimos del curso anterior, siendo evaluada la parte de procedimientos con los resultados obtenidos en el curso donde se encuentre, pero baremados a niveles de exigencia del curso pendiente.

Finalmente, todos aquellos alumnos que no superen la materia por la vía ordinaria deberán presentarse a las pruebas de carácter extraordinario en el mes de junio.

PRUEBA EXTRAORDINARIA DE JUNIO

Los alumnos que no hayan aprobado la asignatura de Educación Física tras las tres evaluaciones ordinarias deberán realizar una prueba extraordinaria en junio. Ésta constará de un examen escrito (cuya nota mínima para hacer media con la prueba práctica habrá de ser de 5), la prueba de flexibilidad de flexión anterior de tronco y una prueba práctica de resistencia aeróbica de carrera continua durante un determinado tiempo previamente estipulado (y durante el cual no se permite la mera marcha: en el momento en el que el alumno deje de correr se dará por finalizada dicha prueba). Las calificaciones se obtendrán de acuerdo con los siguientes baremos:

PRUEBA DE RESISTENCIA						
NOTA	Nacidos en 2005	2004	2003	2002	2001	2000
0	<5'	<5'	<10'	<10'	<15'	<20'
1	7'	8'	13'	14'	19'	24'
2	9'	11'	16'	18'	23'	28'
3	11'	14'	19'	22'	27'	32'
4	13'	17'	22'	26'	31'	36'
5	15'	20'	25'	30'	35'	40'
6	17'	22'	27'	34'	39'	44'
7	19'	24'	29'	38'	43'	48'
8	21'	26'	31'	42'	47'	52'
9	23'	28'	33'	46'	51'	56'
10	25'	30'	40'	50'	55'	1 h

PRUEBA DE FLEXIBILIDAD (hombres)						
NOTA	Nacidos en 2005	2004	2003	2002	2001	2000
0	-12	-11	-10	-9	-8	-7
1	-10	-9	-8	-7	-6	-5
2	-8	-7	-6	-5	-4	-3
3	-6	-5	-4	-3	-2	-1
4	-4	-3	-2	-1	0	1
5	-2	-1	0	1	2	3
6	1	2	3	4	5	6
7	4	5	6	7	8	9
8	6	7	8	9	10	11
9	8	9	10	11	12	13
10	10	11	12	13	14	15

PRUEBA DE FLEXIBILIDAD (mujeres)						
NOTA	Nacidos en 2005	2004	2003	2002	2001	2000
0	-8	-7	-6	-5	-4	-3
1	-6	-5	-4	-3	-2	-1
2	-4	-3	-2	-1	0	1
3	-2	-1	0	1	2	3
4	0	1	2	3	4	5
5	2	3	4	5	6	7
6	5	6	7	8	9	10
7	9	10	11	12	13	14
8	12	13	14	15	16	17
9	14	15	16	17	18	19
10	16	17	18	19	20	21

Recibí criterios de calificación del Dto. De Educación Física

Familia del alumno/a:

Fdo:

FICHA MÉDICA

APELLIDOS _____ **NOMBRE** _____ **CURSO:** _____

EN LA SIGUIENTE FICHA (DE CARÁCTER CONFIDENCIAL Y USO EXCLUSIVO POR EL DEPARTAMENTO DE EDUCACIÓN FÍSICA), DEBE SEÑALAR SI O NO. SOLO SI LA RESPUESTA ES AFIRMATIVA, ROGAMOS CONTESTE A LAS PREGUNTAS. ¡GRACIAS POR SU COLABORACIÓN!

1ª ¿PADECE SU HIJO/A ALGÚN TIPO DE ENFERMEDAD O PROBLEMA CARDIOVASCULAR? **SI NO** EN CASO AFIRMATIVO, SEÑALE CUÁL Y DE QUÉ TIPO

2ª ¿PRESENTA SU HIJO ALGÚN TIPO DE ALERGIA (DE PRIMAVERA U OTRO TIPO) ? **SI NO** SEÑALE CUÁL

3ª ¿PADECE SU HIJO/A ALGÚN TIPO DE ASMA O PROBLEMA RESPIRATORIO? **SI NO** EN CASO AFIRMATIVO SEÑALE CUÁL Y DE QUÉ IMPORTANCIA

4ª ¿PADECE SU HIJO/A ALGÚN TIPO DE LESIÓN O ENFERMEDAD DEL APARATO LOCOMOTOR EN MÚSCULOS, HUESOS Y ARTICULACIONES **SI NO** EN CASO AFIRMATIVO, SEÑALE CUÁL

5ª ¿PADECE SU HIJO/A ALGÚN TIPO DE DESVIACIÓN O PROBLEMA EN LA COLUMNA? **SI NO** SEÑALE DE QUÉ TIPO Y GRADO:

POR ÚLTIMO ¿EXISTE EN LA ACTUALIDAD ALGÚN OTRO TIPO DE PROBLEMA DE SALUD QUE HAGA QUE SU HIJO/A DEBA ACCEDER A UNA ADAPTACIÓN CURRICULAR POR PARTE DEL DEPARTAMENTO DE EDUCACIÓN FÍSICA, PARA CURSAR LA ASIGNATURA DE EDUCACIÓN FÍSICA? **SI NO**

EN CASO DE RESPUESTA AFIRMATIVA EN ALGUNA DE LAS CUESTIONES ENUMERADAS ANTERIORMENTE, Y CON EL OBJETO DE ACCEDER A UNA ADAPTACIÓN QUE PERMITA AL ALUMNO/A CURSAR LA ASIGNATURA EN LAS MEJORES CONDICIONES, DEBE PRESENTAR ANTE EL DEPARTAMENTO DE EDUCACIÓN FÍSICA UN CERTIFICADO MÉDICO OFICIAL EN EL QUE CONSTE: -PATOLOGÍA Y/O ENFERMEDAD -CONTRAINDICACIONES HACIA EL EJERCICIO FÍSICO (QUE TIPO DE EJERCICIOS, DEPORTES Y A QUE INTENSIDAD PUEDE REALIZARLOS) - Y DURACIÓN (SI ES TRANSITORIA) DE LA PATOLOGÍA QUE PROVOCA LA ADAPTACIÓN CURRICULAR.

OTRAS CONSIDERACIONES A EXPONER:

NOMBRE DEL PADRE/MADRE O TUTOR _____
DNI: _____

(EL ABAJO FIRMANTE CERTIFICA QUE TODOS LOS DATOS REFLEJADOS EN EL PRESENTE DOCUMENTO SON VERDADEROS) FIRMA (DEL PADRE/MADRE O TUTOR)

EN _____ A _____ DE _____ DE _____

